



SHEFFER™

PNEUMATIC & HYDRAULIC CYLINDERS



MA SERIES

MEDIUM-DUTY PNEUMATIC CYLINDERS
PRESSURE RATING 200 PSI

1,2 Head & Cap

High strength aluminum alloy is used for both head and cap. They are accurately machined for tube and rod bearing.

3 Piston Rod

Piston rods have a minimum expected yield of 100,000 psi. They are ground, polished and hard chrome plated for wear and corrosion resistance. Four wrench flats are standard.

4 Tube

The tube is a high tensile, special aluminum alloy with a hard anodized finish. The file-hard finish offers long life and amazing lubrication holding properties.

5 Tie Rod Construction

Maximum strength is obtained through a prestressed tie rod assembly.

9 Piston

Pistons are machined from fine grain C.I. for excellent friction characteristics against the hard coated tube I.D. Low friction. The piston is of one-piece design to provide full thickness bearing and is threaded onto the piston rod for strength of assembly.

16 Tube End Seals

Static seals at tube ends are confined, precision cut gaskets.

18 Piston Seals

Modified U-cup seals are Buna-N compound. They are self-adjusting for pressure and wear and their design permits simple replacement.

22 Rod Gland Seal

A Buna-N O-Ring provides a positive, pressure activated, seal for the rod gland.

24 Rod Wiper

The quad ring wiper is designed to wipe off abrasive dust and contamination on the retract stroke to insure long life for the seals, bearing and piston rod.

25 Rod Seal

Modified U-cup design offers long life with minimum friction. It is self-adjusting to pressure and wear. Seal material is a standard Buna-N compound.

70 Rod Bearing

The rod gland has an extra long bearing surface and is easily removed. It is made of a high quality cast iron and Teflon® coated. This affords a low friction bearing which is highly compatible with the hard chrome plated piston rod.

Seal Rating Temperature: -40° to +200°F

FIGURE 1



Sheffer's state-of-the-art cushion design features a unique, one-piece, nitrile compound seal that is captured within a precision machined groove. This allows both linear and radial "float" of the cushion seal which virtually eliminates problems associated with misalignment!

Figure 1 shown with spear entering cushion seal.

↔

Figure 2 shown with spear exiting cushion seal.

Integral flow paths molded in the periphery of the seal provide exceptionally fast "out of cushion" stroke reversal without the use of ball checks.

FIGURE 2

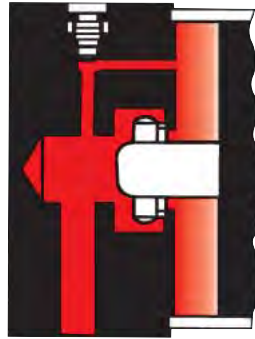

Tie Rod Torque Chart

CYLINDER BORE	TORQUE IN FOOT POUNDS
1 1/2	6
2	10
2 1/2	15
3 1/4	22
4	25
5	40
6	50
8	85

Gland Retainer Torque Chart

ROD DIAMETER	TORQUE IN FOOT POUNDS
5/8	2.8
1	6
1 3/8	13
1 3/4	27

Parts List

ITEM NUMBER	DESCRIPTION	QUANTITY REQUIRED
1	HEAD	1
2	CAP	1
3	PISTON ROD	1
4	TUBE	1
5	TIE ROD	4
6	ROD GLAND RETAINER	1
9	PISTON	1
10	RETAINER SCREW	4
13	TIE ROD NUT	4
16*	TUBE SEAL	2
18*	PISTON SEAL	2
22*	ROD GLAND SEAL	1
24*	ROD WIPER	1
25*	ROD SEAL	1
29	CUSHION PISTON - FRONT	**
30	CUSHION ADJUSTING SCREW	**
31	CUSHION ADJUSTING SCREW SEAL	**
33*	CUSHION SEAL - FRONT	**
43*	CUSHION SEAL - REAR	**
70	ROD BEARING	1

*Recommended Spare Parts

**As required. Specify if cushioned front, cushioned rear, or cushioned both ends.

► Parts List

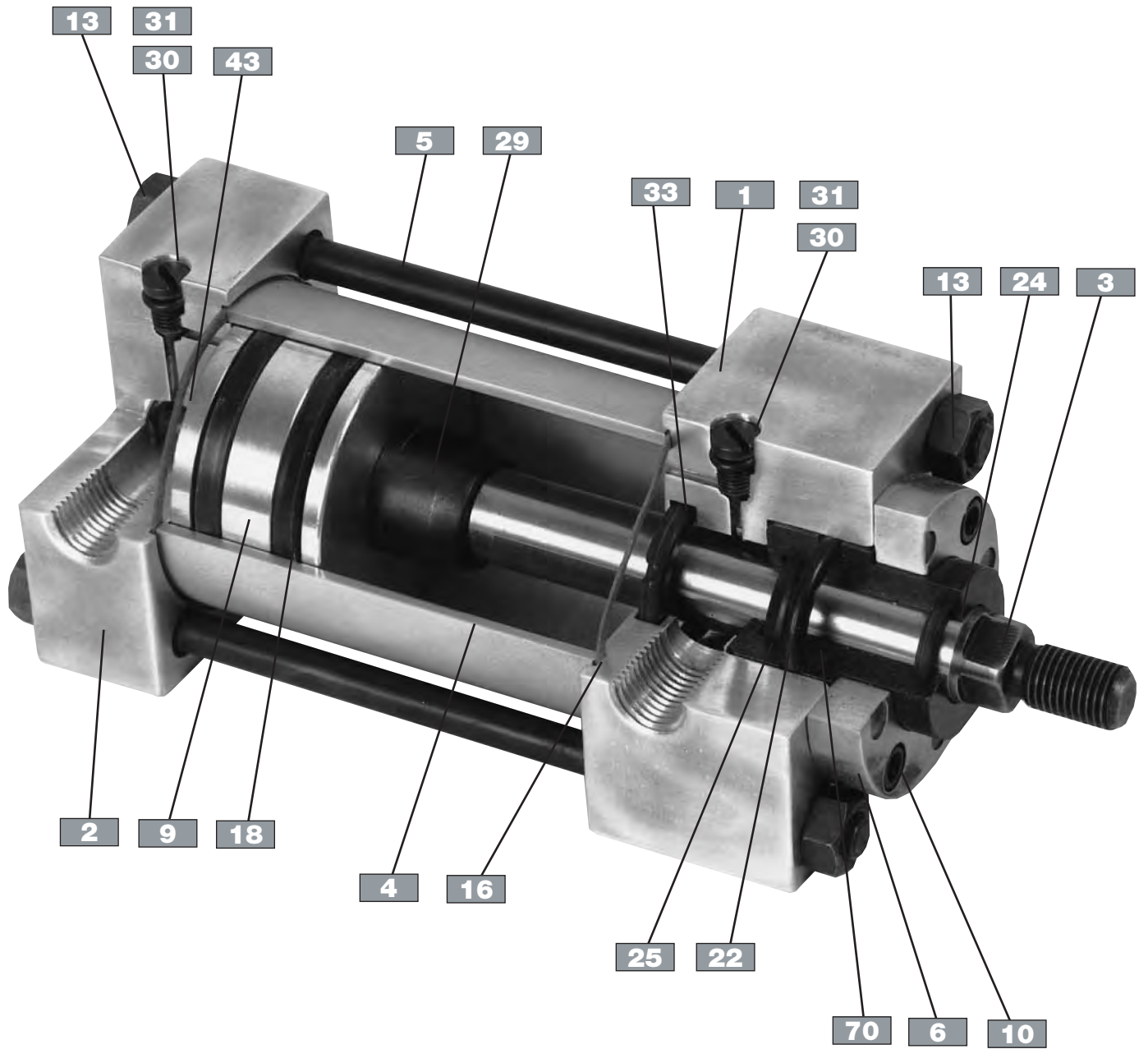

FRONT FLANGE MOUNT STYLE FF (MF1)*

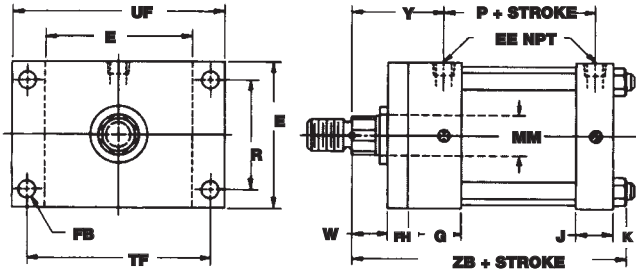

Note: Available in 1 1/2" through 6" bores only.

REAR FLANGE MOUNT STYLE RF (MF2)*

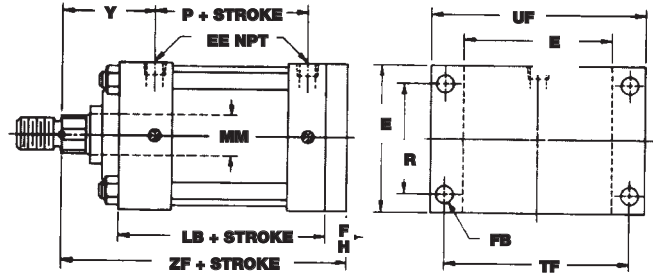

Note: Available in 1 1/2" through 6" bores only.

FRONT HEAD MOUNT STYLE FH (ME3)*

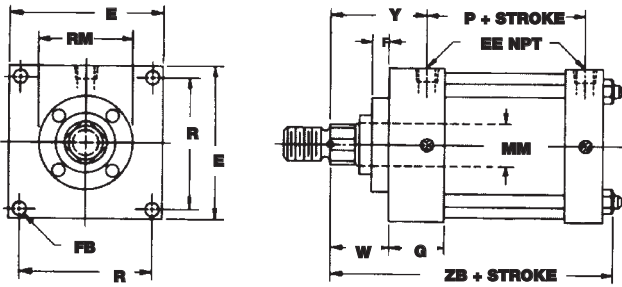

Note: Available in 8" bore only.

REAR HEAD MOUNT STYLE RH (ME4)*

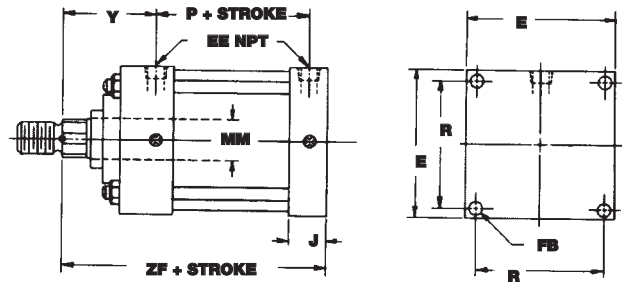

Note: Available in 8" bore only.

TRUNNION FRONT MOUNT STYLE TF (MT1)*

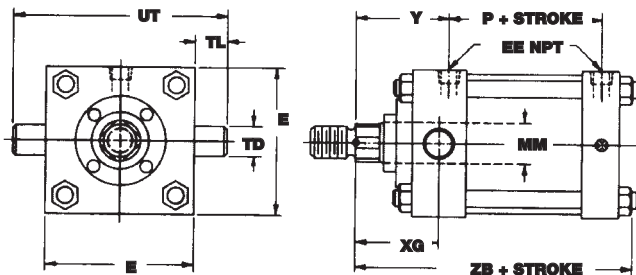

Note: Not available in 1 1/2" bore, or 2" and 3 1/4" bores with oversized rods.

TRUNNION REAR MOUNT STYLE TR (MT2)*

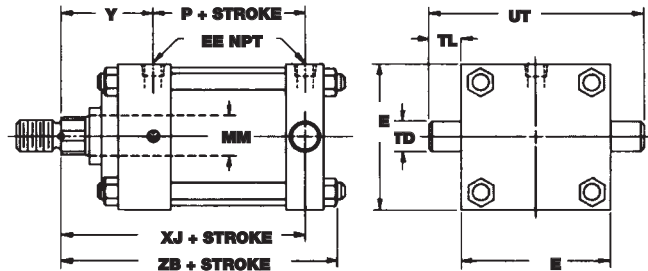

*ANSI designation

Flange and Trunnion Mountings

BORE	1 1/2		2		2 1/2		3 1/4		4		5		6		8	
MM ROD DIA.	5/8	1	5/8	1	5/8	1	1	1 3/8	1	1 3/8	1	1 3/8	1 3/8	1 3/4	1 3/8	1 3/4
A	3/4	1 1/8	3/4	1 1/8	3/4	1 1/8	1 1/8	1 5/8	1 1/8	1 5/8	1 1/8	1 5/8	1 5/8	2	1 5/8	2
B ^{±.000} _{.002}	1.125	1.500	1.125	1.500	1.125	1.500	1.500	2.000	1.500	2.000	1.500	2.000	2.000	2.375	2.000	2.375
C	3/8	1/2	3/8	1/2	3/8	1/2	1/2	5/8	1/2	5/8	1/2	5/8	5/8	3/4	5/8	3/4
CC	1/2-20	7/8-14	1/2-20	7/8-14	1/2-20	7/8-14	7/8-14	1 1/4-12	7/8-14	1 1/4-12	7/8-14	1 1/4-12	1 1/4-12	1 1/2-12	1 1/4-12	1 1/2-12
D	1/2	13/16	1/2	13/16	1/2	13/16	13/16	1 1/8	13/16	1 1/8	13/16	1 1/8	1 1/8	1 1/2	1 1/8	1 1/2
E	2	2	2 1/2	2 1/2	3	3	3 3/4	3 3/4	4 1/2	4 1/2	5 1/2	5 1/2	6 1/2	6 1/2	8 1/2	8 1/2
EE	1/4	1/4	1/4	1/4	1/4	1/4	3/8	3/8	3/8	3/8	3/8	3/8	3/8	1/2	1/2	1/2
F	3/8	3/8	3/8	3/8	3/8	3/8	5/8	5/8	5/8	5/8	5/8	5/8	5/8	3/4	5/8	3/4
FB	5/16	5/16	3/8	3/8	3/8	3/8	7/16	7/16	7/16	7/16	9/16	9/16	9/16	9/16	11/16	11/16
FH	3/8	3/8	3/8	3/8	3/8	3/8	5/8	5/8	5/8	5/8	5/8	5/8	5/8	3/4	3/4	—
G	1 1/2	1 1/2	1 1/2	1 1/2	1 1/2	1 1/2	1 3/4	1 3/4	1 3/4	1 3/4	1 3/4	1 3/4	1 3/4	2	2	2
J	1	1	1	1	1	1	1 1/4	1 1/4	1 1/4	1 1/4	1 1/4	1 1/4	1 1/4	1 1/2	1 1/2	1 1/2
K	1/4	1/4	5/16	5/16	5/16	5/16	5/16	5/16	5/16	5/16	5/16	5/16	5/16	1/2	1/2	5/8
KK	7/16-20	3/4-16	7/16-20	3/4-16	7/16-20	3/4-16	3/4-16	1-14	3/4-16	1-14	3/4-16	1-14	1-14	1-14	1 1/4-12	1-14
LB	3 5/8	3 5/8	3 5/8	3 5/8	3 3/4	3 3/4	4 1/4	4 1/4	4 1/4	4 1/4	4 1/2	4 1/2	5	5	5 1/8	5 1/8
NA±.002	.594	.968	.594	.968	.594	.968	.968	1.343	.968	1.343	.968	1.343	1.343	1.703	1.343	1.703
P	2 1/8	2 1/8	2 1/8	2 1/8	2 1/4	2 1/4	2 5/8	2 5/8	2 5/8	2 5/8	2 7/8	2 7/8	3	3	3 1/8	3 1/8
R	1.43	1.43	1.84	1.84	2.19	2.19	2.76	2.76	3.32	3.32	4.10	4.10	4.88	4.88	7.57	7.57
RM	2 SQ.	2 SQ.	2	2 1/2 SQ.	2	3 SQ.	2 5/8	3 3/8	2 5/8	3 3/8	2 5/8	3 3/8	3 3/8	4	3 3/8	4
TD	1	1	1	1	1	1	1	1	1	1	1	1	1 3/8	1 3/8	1 3/8	1 3/8
TF	2 3/4	2 3/4	3 3/8	3 3/8	3 7/8	3 7/8	4 11/16	4 11/16	5 7/16	5 7/16	6 5/8	6 5/8	7 5/8	7 5/8	—	—
TL	1	1	1	1	1	1	1	1	1	1	1	1	1 3/8	1 3/8	1 3/8	1 3/8
UF	3 3/8	3 3/8	4 1/8	4 1/8	4 5/8	4 5/8	5 1/2	5 1/2	6 1/4	6 1/4	7 5/8	7 5/8	8 5/8	8 5/8	—	—
UT	4	4	4 1/2	4 1/2	5	5	5 3/4	5 3/4	6 1/2	6 1/2	7 1/2	7 1/2	9 1/4	9 1/4	11 1/4	11 1/4
V	1/4	1/2	1/4	1/2	1/4	1/2	1/4	3/8	1/4	3/8	1/4	3/8	1/4	3/8	3/8	3/8
W	5/8	1	5/8	1	5/8	1	3/4	1	3/4	1	3/4	1	7/8	1 1/8	1 5/8	1 7/8
XG	—	—	1 3/4	—	1 3/4	2 1/8	2 1/4	—	2 1/4	2 1/2	2 1/4	2 1/2	2 5/8	2 7/8	2 5/8	2 7/8
XJ	4 1/8	4 1/2	4 1/8	4 1/2	4 1/4	4 5/8	5	5 1/4	5	5 1/4	5 1/4	5 1/2	5 7/8	6 1/8	6	6 1/4
Y	2	2 3/8	2	2 3/8	2	2 3/8	2 7/16	2 11/16	2 7/16	2 11/16	2 7/16	2 11/16	2 7/8	3 1/8	2 7/8	3
ZB	4 7/8	5 1/4	4 15/16	5 5/16	5 1/16	5 7/16	5 15/16	6 3/16	5 15/16	6 3/16	6 5/16	6 9/16	7 1/8	7 3/8	7 5/16	7 9/16
ZF	5	5 3/8	5	5 3/8	5 1/8	5 1/2	6 1/4	6 1/2	6 1/4	6 1/2	6 1/2	6 3/4	7 3/8	7 5/8	6 3/4	7

Standard and Alternate Rod End Styles

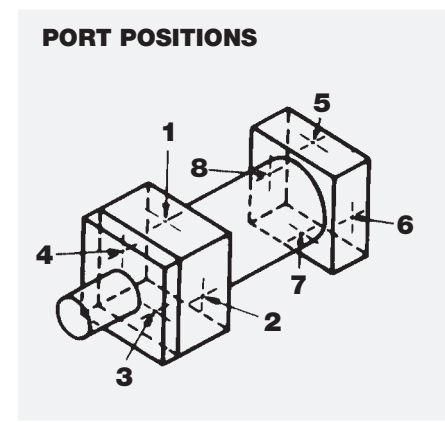
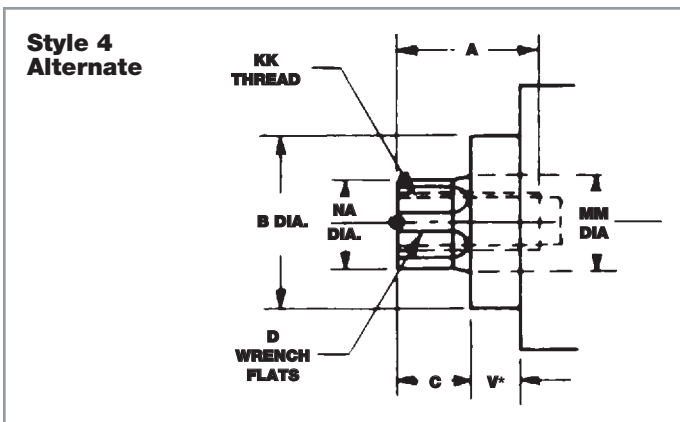
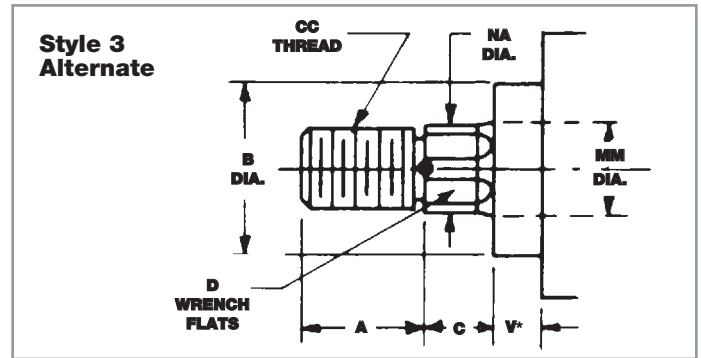
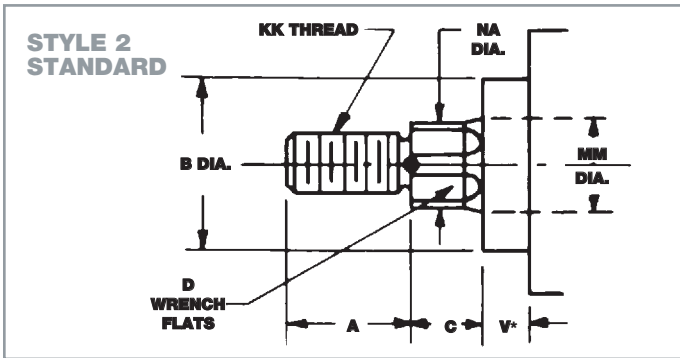

Ports are provided in positions 1 and 5. When a cylinder is cushioned, cushion adjusting screws will be located in positions 2 and 6. Cushion not available at head end of 1 1/2" bore with 1" diameter rod.

Note: Style 2 rod end is standard and will be supplied unless otherwise ordered. Threaded studs for use with Style 4 rod ends are available.

CLEVIS MOUNT STYLE C (MP1)*

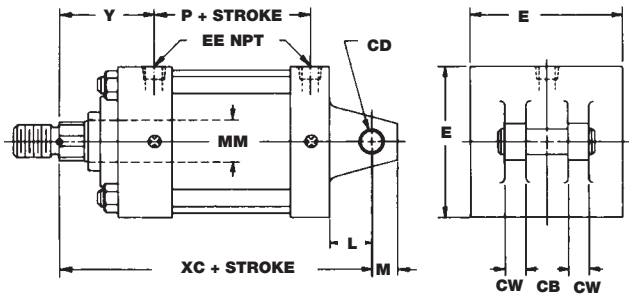

Note: Matching clevis pin and retainers are included.

SIDE FLUSH MOUNT STYLE SF (MS4)*

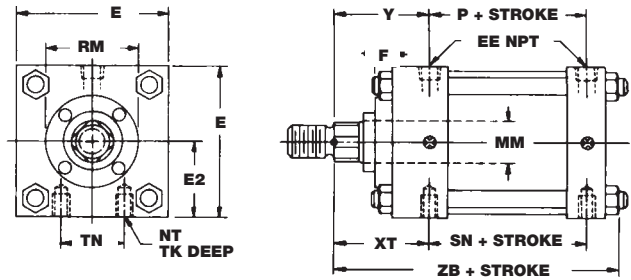

Note: Not available in the 1 1/2" bore with 1" diameter rod.

SIDE LUG MOUNT STYLE SL (MS2)*

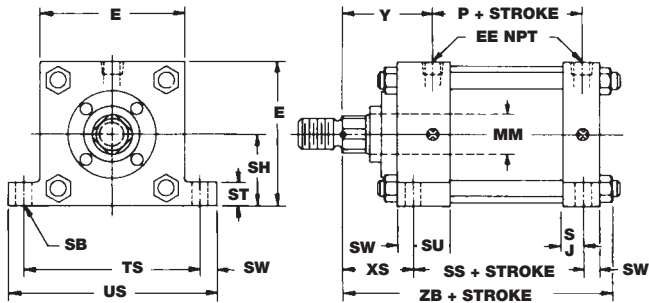

Note: 1 1/2" through 4" bores only.

TIE RODS EXTENDED MOUNTS

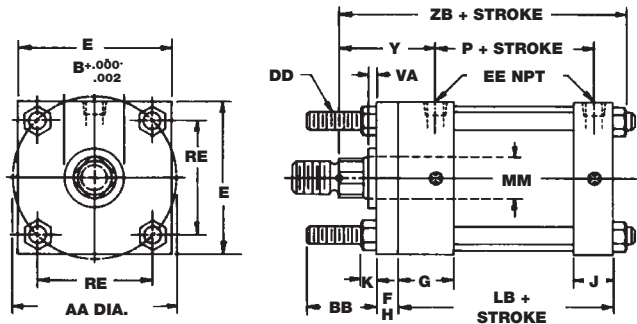

Extended Front Mount - Style FX (ANSI MX3)
 Extended Rear Mount - Style RX (ANSI MX2)
 Extended Both Mount - Style BX (ANSI MX1)
 Extended Neither Mount - Style NX (ANSI MX0)

Note: On the 8" bore only, a full size square retainer is not employed and **BB** is measured from head.

FOOT BRACKET MOUNT STYLE FB (MS1)*

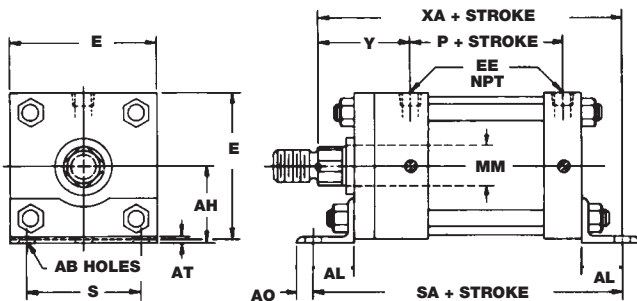

Note: On the 8" bore only, a full size square retainer is not employed and **AL** is measured from head. Not available in the 1 1/2" bore with 1" diameter rod.

*ANSI designation

Clevis, Side Flush, Side Lug, Foot Bracket and Tie Rod Extended Dimensions

BORE MM ROD DIA.	1 1/2		2		2 1/2		3 1/4		4		5		6		8	
	5/8	1	5/8	1	5/8	1	1	1 3/8	1	1 3/8	1	1 3/8	1 3/8	1 3/4	1 3/8	1 3/4
A	3/4	1 1/8	3/4	1 1/8	3/4	1 1/8	1 1/8	1 5/8	1 1/8	1 5/8	1 1/8	1 5/8	1 5/8	2	1 5/8	2
AA	2.02	2.02	2.6	2.6	3.1	3.1	3.90	3.90	4.70	4.70	5.80	5.80	6.9	6.9	9.1	9.1
AB	7/16	—	7/16	7/16	7/16	7/16	9/16	9/16	9/16	9/16	11/16	11/16	13/16	13/16	13/16	13/16
AH	1 3/16	—	1 7/16	1 7/16	1 5/8	1 5/8	1 15/16	1 15/16	2 1/4	2 1/4	2 3/4	2 3/4	3 1/4	3 1/4	4 1/4	4 1/4
AL	1	—	1	1	1	1	1 1/4	1 1/4	1 1/4	1 1/4	1 3/8	1 3/8	1 3/8	1 3/8	1 13/16	1 13/16
AO	3/8	—	3/8	3/8	3/8	3/8	1/2	1/2	1/2	1/2	5/8	5/8	5/8	5/8	1 1/16	1 1/16
AT	1/8	—	1/8	1/8	1/8	1/8	1/8	1/8	1/8	1/8	3/16	3/16	3/16	3/16	1/4	1/4
B ^{±.000}	1.125	1.500	1.125	1.500	1.125	1.500	1.500	2.000	1.500	2.000	1.500	2.000	2.000	2.375	2.000	2.375
BB	1	1	1 1/8	1 1/8	1 1/8	1 1/8	1 3/8	1 3/8	1 3/8	1 3/8	1 13/16	1 13/16	1 13/16	1 13/16	2 5/16	2 5/16
C	3/8	1/2	3/8	1/2	3/8	1/2	1/2	5/8	1/2	5/8	1/2	5/8	5/8	3/4	5/8	3/4
CB	3/4	3/4	3/4	3/4	3/4	3/4	1 1/4	1 1/4	1 1/4	1 1/4	1 1/4	1 1/4	1 1/2	1 1/2	1 1/2	1 1/2
CC	1 1/2-20	7/8-14	1 1/2-20	7/8-14	1 1/2-20	7/8-14	7/8-14	1 1/4-12	7/8-14	1 1/4-12	7/8-14	1 1/4-12	1 1/4-12	1 1/2-12	1 1/4-12	1 1/2-12
CD	1/2	1/2	1/2	1/2	1/2	1/2	3/4	3/4	3/4	3/4	3/4	3/4	3/4	1	1	1
CW	1/2	1/2	1/2	1/2	1/2	1/2	5/8	5/8	5/8	5/8	5/8	5/8	5/8	3/4	3/4	3/4
D	1/2	1 3/16	1/2	1 3/16	1/2	1 3/16	1 3/16	1 1/8	1 3/16	1 1/8	1 3/16	1 1/8	1 1/8	1 1/2	1 1/8	1 1/2
DD	1 1/4-28	1 1/4-28	5/16-24	5/16-24	5/16-24	5/16-24	3/8-24	3/8-24	3/8-24	3/8-24	1/2-20	1/2-20	1/2-20	1/2-20	5/8-18	5/8-18
E	2	2	2 1/2	2 1/2	3	3	3 3/4	3 3/4	4 1/2	4 1/2	5 1/2	5 1/2	6 1/2	6 1/2	8 1/2	8 1/2
EE	1/4	1/4	1/4	1/4	1/4	1/4	3/8	3/8	3/8	3/8	3/8	3/8	1/2	1/2	1/2	1/2
F	3/8	3/8	3/8	3/8	3/8	3/8	5/8	5/8	5/8	5/8	5/8	5/8	5/8	3/4	5/8	3/4
FH	3/8	3/8	3/8	3/8	3/8	3/8	5/8	5/8	5/8	5/8	5/8	5/8	3/4	3/4	5/8	3/4
G	1 1/2	1 1/2	1 1/2	1 1/2	1 1/2	1 1/2	1 3/4	1 3/4	1 3/4	1 3/4	1 3/4	1 3/4	2	2	2	2
J	1	1	1	1	1	1	1 1/4	1 1/4	1 1/4	1 1/4	1 1/4	1 1/4	1 1/2	1 1/2	1 1/2	1 1/2
K	1/4	1/4	5/16	5/16	5/16	5/16	5/16	5/16	5/16	5/16	7/16	7/16	1/2	1/2	5/8	5/8
KK	7/16-20	3/4-16	7/16-20	3/4-16	7/16-20	3/4-16	3/4-16	1-14	3/4-16	1-14	3/4-16	1-14	1-14	1 1/4-12	1-14	1 1/4-12
L	3/4	3/4	3/4	3/4	3/4	3/4	1 1/4	1 1/4	1 1/4	1 1/4	1 1/4	1 1/4	1 1/2	1 1/2	1 1/2	1 1/2
LB	3 5/8	3 5/8	3 5/8	3 5/8	3 3/4	3 3/4	4 1/4	4 1/4	4 1/4	4 1/4	4 1/2	4 1/2	5	5	5 1/8	5 1/8
M	5/8	5/8	5/8	5/8	5/8	5/8	7/8	7/8	7/8	7/8	3/4	3/4	1	1	1	1
NA ^{±.002}	.594	.968	.594	.968	.594	.968	.968	1.343	.968	1.343	.968	1.343	1.343	1.703	1.343	1.703
NT	1 1/4-20	—	5/16-18	5/16-18	3/8-16	3/8-16	1/2-13	1/2-13	1/2-13	1/2-13	5/8-11	5/8-11	3/4-10	3/4-10	3/4-10	3/4-10
P	2 1/8	2 1/8	2 1/8	2 1/8	2 1/4	2 1/4	2 5/8	2 5/8	2 5/8	2 5/8	2 7/8	2 7/8	3	3	3 1/8	3 1/8
RE	1.43	1.43	1.84	1.84	2.19	2.19	2.76	2.76	3.32	3.32	4.10	4.10	4.88	4.88	6.44	6.44
RM	2 SQ.	2 SQ.	2	2 1/2 SQ.	2	3 SQ.	2 5/8	3 3/8	2 5/8	3 3/8	2 5/8	3 3/8	3 3/8	4	3 3/8	4
S	1 1/4	—	1 3/4	1 3/4	2 1/4	2 1/4	2 3/4	2 3/4	3 1/2	3 1/2	4 1/4	4 1/4	5 1/4	5 1/4	7 1/8	7 1/8
SA	6	—	6	6	6 1/8	6 1/8	7 3/8	7 3/8	7 3/8	7 3/8	7 7/8	7 7/8	8 1/2	8 1/2	8 3/4	8 3/4
SB	7/16	7/16	7/16	7/16	7/16	7/16	9/16	9/16	9/16	9/16	—	—	—	—	—	—
SH	1	1	1 1/4	1 1/4	1 1/2	1 1/2	1 7/8	1 7/8	2 1/4	2 1/4	—	—	—	—	—	—
SJ	5/8	5/8	5/8	5/8	5/8	5/8	3/4	3/4	3/4	3/4	—	—	—	—	—	—
SN	2 1/4	—	2 1/4	2 1/4	2 3/8	2 3/8	2 5/8	2 5/8	2 5/8	2 5/8	2 7/8	2 7/8	3 1/8	3 1/8	3 1/4	3 1/4
SS	2 7/8	2 7/8	2 7/8	2 7/8	3	3	3 1/4	3 1/4	3 1/4	3 1/4	—	—	—	—	—	—
ST	1/2	1/2	1/2	1/2	1/2	1/2	3/4	3/4	3/4	3/4	—	—	—	—	—	—
SU	1 1/8	1 1/8	1 1/8	1 1/8	1 1/8	1 1/8	1 1/4	1 1/4	1 1/4	1 1/4	—	—	—	—	—	—
SW	3/8	3/8	3/8	3/8	3/8	3/8	1/2	1/2	1/2	1/2	—	—	—	—	—	—
TK	3/8	—	1/2	7/16	5/8	1/2	3/4	3/4	3/4	3/4	1	1	1 1/8	1 1/8	1 1/8	1 1/8
TN	5/8	—	7/8	7/8	1 1/4	1 1/4	1 1/2	1 1/2	2 1/16	2 1/16	2 11/16	2 11/16	3 1/4	3 1/4	4 1/2	4 1/2
TS	2 3/4	2 3/4	3 1/4	3 1/4	3 3/4	3 3/4	4 3/4	4 3/4	5 1/2	5 1/2	—	—	—	—	—	—
US	3 1/2	3 1/2	4	4	4 1/2	4 1/2	5 3/4	5 3/4	6 1/2	6 1/2	—	—	—	—	—	—
V	1/4	1/2	1/4	1/2	1/4	1/2	1/4	3/8	1/4	3/8	1/4	3/8	3/8	3/8	3/8	3/8
VA	1/4	1/2	1/4	1/2	1/4	1/2	1/4	3/8	1/4	3/8	1/4	3/8	1/4	3/8	1/4	3/8
XA	5 5/8	—	5 5/8	6	5 3/4	6 1/8	6 7/8	7 1/8	6 7/8	7 1/8	7	7 1/4	8	8 1/4	8 9/16	8 13/16
XC	5 3/8	5 3/4	5 3/8	5 3/4	5 1/2	5 7/8	6 7/8	7 1/8	6 7/8	7 1/8	7 1/8	7 3/8	8 1/8	8 3/8	8 1/4	8 1/2
XS	1 3/8	1 3/4	1 3/8	1 3/4	1 3/8	1 3/4	1 7/8	2 1/8	1 7/8	2 1/8	—	—	—	—	—	—
XT	1 15/16	—	1 15/16	2 5/16	1 15/16	2 5/16	2 7/16	2 11/16	2 7/16	2 11/16	2 7/16	2 11/16	2 13/16	3 1/16	2 13/16	3 1/16
Y	2	2 3/8	2	2 3/8	2	2 3/8	2 7/16	2 11/16	2 7/16	2 11/16	2 7/16	2 11/16	2 7/8	3 1/8	2 7/8	3
ZB	4 7/8	5 1/4	4 15/16	5 5/16	5 1/16	5 7/16	5 15/16	6 3/16	5 15/16	6 3/16	6 5/16	6 9/16	7 1/8	7 3/8	7 5/16	7 9/16

See Page MA-4 for Rod End Styles and Porting diagrams and information.

► Model Number

COMPOSITION

2½ C20 FF 25 CC W

Bore	Cylinder Series	Mounting	Stroke	Cushion	Modification
As Required Use Fractions Where Required	A Heavy Duty Pneumatic AA 200 PSI Pneumatic CLA Heavy Duty Pneumatic CLH Heavy Duty, 250 Pneumatic/1500 Hydraulic C20 Heavy Duty Pneumatic, Cast Iron HH Heavy Duty Hydraulic MA Medium Duty Pneumatic MH Medium Pressure Hydraulic	Listed Below	As Required Use Fractions Where Required Shown as Gross Stroke Including Dual Piston or Stop Tube Length	CF – Cushion Front CR – Cushion Rear CC – Cushion Both Ends	A – Variation in Ports D – Double Rod Extension K – Any Variation in Rod from Standard. Any Variation from Standard Style 2 Rod End. M – Variation in Mounting P – NPT Ports S – Spring Return V – Viton Seals W – Water Fitted Y – Variation in Construction

Mounting Styles

BX – Basic Cylinder, Tie Rods Extended, Both Ends
C – Clevis
CL – Center Line Lug
EL – End Lug
FB – Foot Bracket
FF – Front Flange
FFX – Front Flange, Extra Size
FH – Front Head (7" thru 14" A and MH - 16" thru 24" HH)

FHF – Front Head Flange
FX – Basic Cylinder, Tie Rods Extended, Front End
NX – Basic Cylinder, No Tie Rod Extension
P – Pivot
RF – Rear Flange
RFX – Rear Flange, Extra Size
RH – Rear Head (7" thru 14" A and MH - 16" thru 24" HH)

RHF – Rear Head Flange
RX – Basic Cylinder, Tie Rods Extended, Rear End
SF – Side Flush
SL – Side Lug
SP – Sub Plate
T – Trunnion, Between Heads
TF – Trunnion, Front
TR – Trunnion, Rear

Order Information

To insure prompt delivery, please **BE SURE TO INCLUDE THIS INFORMATION WHEN ORDERING:**

- | | | |
|--|---|---|
| 1. Quantity | 8. Rod End Style (if other than Style 2 standard) | 14. Medium (air, oil, water or other) |
| 2. Series | 9. Rod Size (standard, oversize or 2:1) | 15. Type of fluid |
| 3. Bore | 10. <i>Extra</i> Rod Extension (where required) | 16. Operating Pressure and Maximum Shock Pressure |
| 4. Stroke - Gross Stroke always shown in Model Number | 11. Port Size (if other than standard) | 17. Temperature |
| 5. Dual Piston or Stop Tube when necessary - always give Gross and Net Strokes | 12. Port Positions other than standard positions 1 and 5. | 18. Double rod extension (when required) |
| 6. Mounting Style | 13. Cushion check, adjusting screw, and bleed positions (when required) if other than standard positions. | 19. XI dimension on all Trunnion (between head) cylinders |
| 7. Cushion (front, rear, both or none) | | 20. Delivery required, or scheduling |

Complete and correct ordering information will eliminate untimely delays. When in doubt, always contact local distributor or factory. Contact distributor for helpful order or inquiry form.

Policy:

The policy of the Sheffer Corporation is one of continual improvement in design and manufacture to assure still finer products, hence, specifications are subject to change without notice.

Limited Warranty:

Sheffer warrants its products to be free from defects in material and workmanship for a period of one year from the date of shipment. This warranty does not cover field labor charges for parts removal and replacement, adjustments, repairs or other work, corrosion, electrolysis, mineral deposits or normal deterioration, misapplication, modification, or change in original operating conditions; components supplied by others; defects in parts resulting from abuse, negligence, neglect, accident, fire or explosion, or seals and other components subject to normal wear.

The sole and exclusive remedy against Sheffer shall be for the repair or replacement of parts returned transportation prepaid to Sheffer's factory and found by Sheffer to be defective. Replacement parts provided shall not extend the warranty period for said parts or for the total unit.

IN CONSIDERATION OF THIS EXPRESS WARRANTY NO OTHER REMEDY (INCLUDING BUT NOT LIMITED TO INCIDENTAL OR CONSEQUENTIAL DAMAGES) SHALL BE AVAILABLE. THIS WARRANTY SHALL BE IN LIEU OF ANY AND ALL OTHER WARRANTIES, EXPRESS OR IMPLIED, INCLUDING, BUT NOT LIMITED TO, ANY IMPLIED WARRANTY OF MERCHANTABILITY OR FITNESS FOR A PARTICULAR PURPOSE, AND OF ALL OTHER OBLIGATIONS ON THE PART OF SHEFFER.

Sheffer neither assumes, nor authorizes any person to assume for it, any other obligation or warranty.



THE SHEFFER CORPORATION
6990 CORNELL ROAD • CINCINNATI, OHIO 45242
(513) 489-9770 • FAX: (513) 489-3034
SHEFFERCORP.COM