



***MH SERIES  
Medium-Duty  
Hydraulic  
Cylinders***

*Pressure Rating 800 - 2,000 PSI*



### 3 Piston Rod

Piston rods through 4" diameter have a minimum expected yield of 100,000 psi. They are case hardened to 50 Rockwell C to a depth of .030" for damage resistance. They are then hard chrome plated for wear and corrosion resistance. Larger diameter rods have an expected minimum yield of 50,000 to 60,000 psi depending on diameter and are hard chrome plated.

### 3A Studded Rod End

Offers much longer fatigue life through elimination of thread relief stress concentration point. Standard as Style 2 rod end on all rod sizes through 2½" diameter. Studs are pretorqued and locked in to prevent loosening. They are machined from high tensile steel and the threads rolled.

### 4 Tube

The steel tube is honed to an 8 to 16 microinch finish for low friction and long seal and piston bearing life. Tube ends are machined on the O. D. concentric with the I. D. They are confined by the close tolerance machining of the head and cap which provides greater hoop strength.

### 5 Tie Rod Construction

Maximum strength is obtained through a prestressed tie rod assembly.

### 7 Wrench Flats

Four wrench flats are provided as standard for easy attachment. Spanner holes, in lieu of flats, are standard on large diameter rods.

### 9&18 Pistons & Piston Seals

All pistons are machined from a fine grain alloy cast iron. They are threaded directly onto the piston rod, torqued, sealed and locked in place with one or more set screws.

The *special piston seal* is an endless glass filled Teflon material with an O-ring expander. One or more (depending on bore size) bronze filled Teflon bearing strips are also employed on this type piston to eliminate metal-to-metal contact. This type piston offers long life, low friction, near zero leakage, and great tolerance for side loading. It can be used successfully on virtually any application.

### 16,22 Static Seals

Pressure activated O-ring seals are used at rod gland and tube ends. Located to eliminate extrusion and to provide positive leak tight seal.

### 21 Rod Bearing

High load bearing bronze piloted into the head. Located inboard of the seals to insure a well lubricated bearing for the fastest cycling applications. It need not be removed for rod seal replacement.

### 24 Rod Wiper

The polyurethane wiper is designed to wipe off abrasive dust and contaminants on the retract stroke to insure long life for packings, rod bearing, and piston rod. Where the rod will be exposed to gummy materials such as road tar, a metallic rod scraper is available.

### 25 Rod Seal

The polyurethane rod seal has a unique design which incorporates the optimum sealing properties of a U configuration with the elastomeric properties of a compression-type seal. The polyurethane material was selected for toughness, abrasion resistance, and the ability to resist extrusion under rough service conditions.

### 29 Cushions

Cushion pistons (29) are tapered to provide gradual deceleration and eliminate shock upon entrance. The **Adjusting Screw** with fine threads (30, 40) provides a wide range of adjustment. It is interchangeable with the **Ball Check** (36, 46) permitting field changes of position. Neither the adjusting screw nor ball check plug project beyond the head or cap surface.

### 58 Air Bleeds (Optional)

When required, air bleeds are located where they can be employed most successfully – at the tube and head juncture. The straight thread plugs are equipped with metallic O-rings so they can be used repeatedly with a good seal every time.

### 70 Rod Gland

Easily removable for replacement of rod seal and wiper. In most cases it is not necessary to demount or disassemble the cylinder. Easier to service since on removal of the ductile iron gland, the piston rod remains supported by the separate rod bearing.

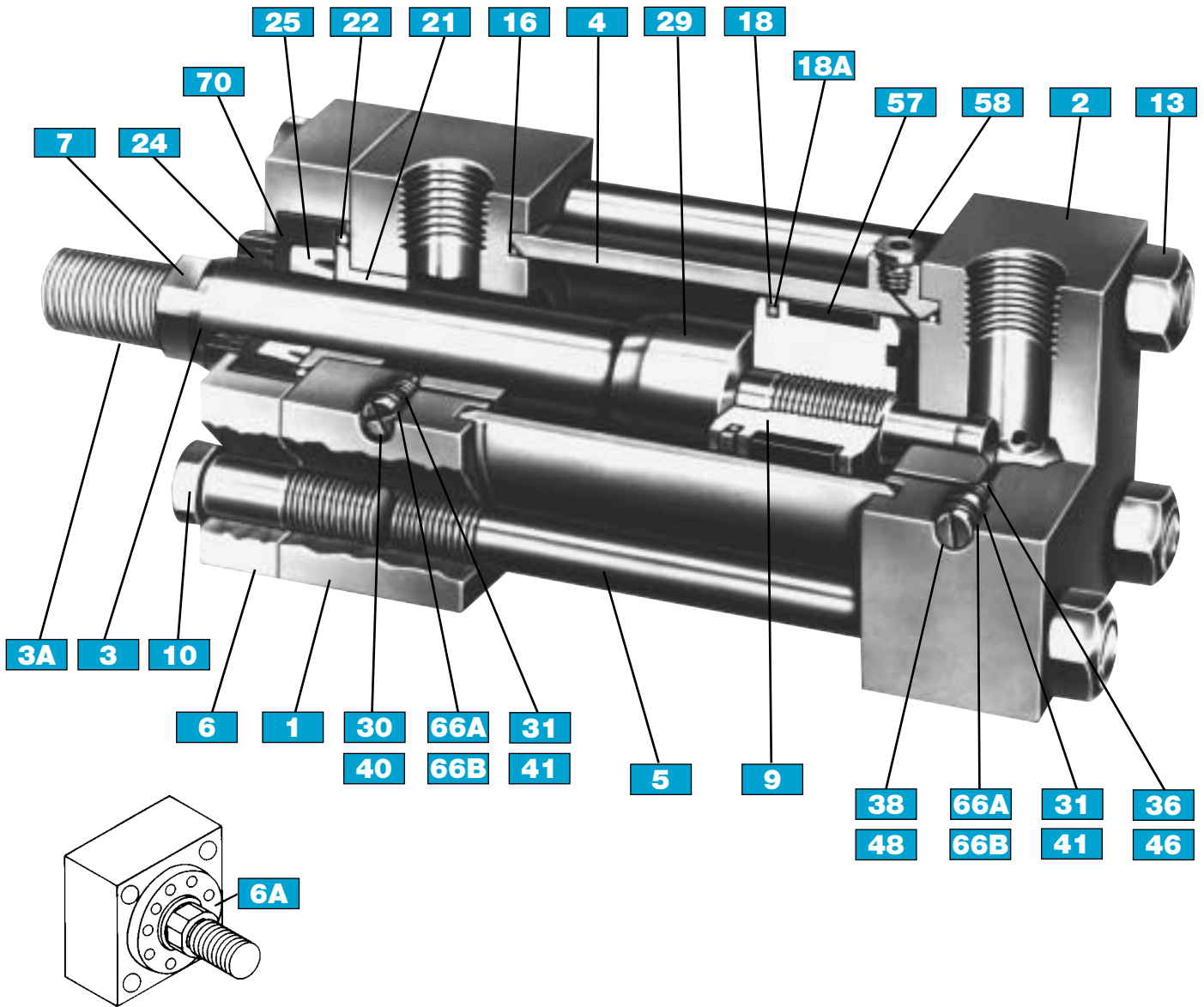
## Parts List

ITEM NUMBER	DESCRIPTION	QUANTITY REQUIRED
1	HEAD	1
2	CAP	1
3	PISTON ROD	1
3 A	STUD – STYLE II THREAD THRU 2½" ROD DIA.	1
4	TUBE	1
5	TIE ROD	4
6	ROD GLAND RETAINER	1
6 A	ROD GLAND AND RETAINER – SINGLE PIECE	1
9	PISTON – SLIPPER SEAL TYPE	1
10	RETAINER SCREW	‡
13	TIE ROD NUT	4
16 †	TUBE SEAL	2
18 †	PISTON SEAL – SLIPPER SEAL TYPE	1
18 A †	EXPANDER – FOR SLIPPER SEAL	1
21 †	ROD BEARING	1
22 †	ROD GLAND SEAL	1
24 †	ROD WIPER	1
25 †	ROD SEAL	1
29	CUSHION PISTON – FRONT	**
30	CUSHION ADJ. SCREW – FRONT (CROSS SLOT)	**
31	SEAL – CUSHION ADJUSTING AND CUSHION CHECK – FRONT	**
36	CUSHION CHECK BALL – FRONT	**
38	CUSHION CHECK PLUG – FRONT	**
40	CUSHION ADJ. SCREW – REAR (CROSS SLOT)	**
41	SEAL – CUSHION ADJUSTING AND CUSHION CHECK – REAR	**
46	CUSHION CHECK BALL – REAR	**
48	CUSHION CHECK PLUG – REAR	**
57	PISTON BEARING STRIP	1
58	AIR BLEED PLUG	**
66 A	BACK-UP WASHER – CUSHION ADJUSTING AND CHECK – FRONT	**
66 B	BACK-UP WASHER – CUSHION ADJUSTING AND CHECK – REAR	**
70	ROD GLAND	1

‡Retainer Screws required varies by bore and mount

†Recommended Spare Parts

\*\*As required; specify if cushioned front, cushioned rear or cushioned both ends.



Round, single piece rod gland and retainer used on all but some of the smaller bore sizes. Consult pages on specific mounts.

### Please Note:

Complete replacement packing kits are available. For purposes of economy and less down-time, it is recommended that replacement packing kits be stocked. They are described and priced in the current Sheffer Replacement Parts Price List. Contact your distributor or the factory for these lists.

### Ordering Information:

Also see separate ordering information. When ordering parts, the Model No. and Serial No. must be specified. Give item no., name and quantity of part desired. The Model No. and Serial No. will be found on a metal plate that has been drive-screwed to either the head or the cartridge retainer.

# Parts List

## Parts List

ITEM NUMBER	DESCRIPTION	QTY. REQ'D
100	FRONT FLANGE	1
102	FRONT FLANGE EXTRA	1
103	REAR FLANGE	1
104	REAR FLANGE EXTRA	1
105	FOOT BRACKET - FRONT	1
106	FOOT BRACKET - SCREW	2
107	FOOT BRACKET - REAR	1
112	CLEVIS PIN	1
117	INTERMEDIATE TRUNNION	1
108	END LUG - FRONT	2
110	END LUG - REAR	2

## Tie Rod Torque in Foot Pounds

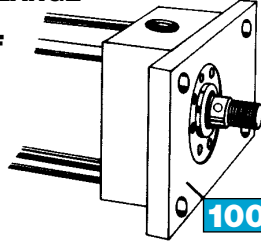
BORE	TORQUE
1 1/8	8
1 1/2	8
2	15
2 1/2	15
3 1/4	30
4	30
5	55
6	60
7	140
8	140

## Specifications Rod Gland Retainer Screw Torque Information

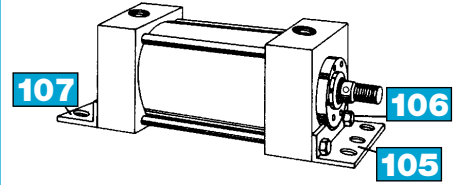
### Screw Torque in Foot Pounds

BORE SIZE	PISTON ROD DIAMETER	HEX HEAD CAP SCREW	SOCKET HEAD CAP SCREW
1 1/8	5/8		7.7
1 1/2	ALL	4.0	
2	ALL	7.5	
2 1/2	5/8, 1		4.5
	1 3/8, 1 3/4	7.5	
3 1/4	1, 1 3/8, 1 3/4		4.5
	2	13.5	
4	ALL		4.5
5	1, 1 3/8, 1 3/4, 2, 2 1/2		4.5
	3, 3 1/2		8.0
6	1 3/8, 1 3/4, 2, 2 1/2		4.5
	3, 3 1/2, 4		8.0
7	1 3/8, 1 3/4, 2, 2 1/2		4.5
	3, 3 1/2, 4, 4 1/2, 5		8.0
8	1 3/8, 1 3/4, 2, 2 1/2		4.5
	3, 3 1/2, 4, 4 1/2, 5, 5 1/2		8.0

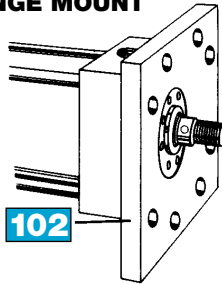
**FRONT FLANGE MOUNT STYLE FF**



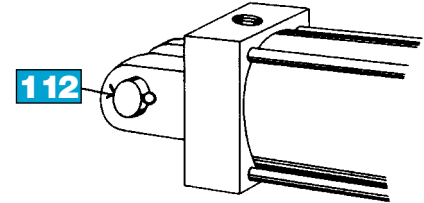
**FOOT BRACKET MOUNT STYLE FB**



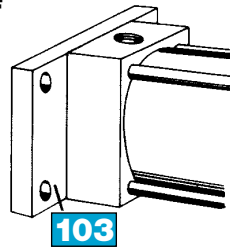
**FRONT FLANGE MOUNT EXTRA SIZE STYLE FFX**



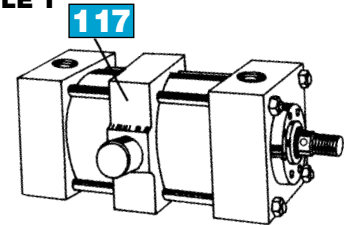
**CLEVIS MOUNT STYLE C**



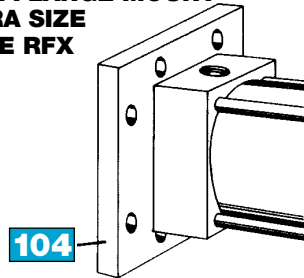
**REAR FLANGE MOUNT STYLE RF**



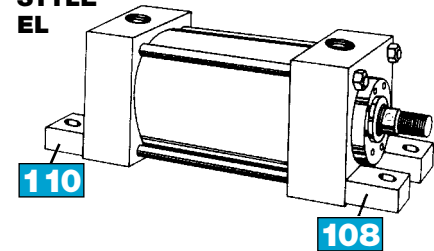
**INTERMEDIATE TRUNNION MOUNT STYLE T**



**REAR FLANGE MOUNT EXTRA SIZE STYLE RFX**



**END LUG MOUNT STYLE EL**



## Retainer Screw Chart

BORE SIZE	ROD DIAMETER	NUMBER
1 1/8, 1 1/2, 2, 2 1/2	ALL	4
3 1/4	1, 2	4
3 1/4	1 3/8, 1 3/4	8
4	1	4
4	1 3/8, 1 3/4, 2, 2 1/2	8
5	1	4
6	ALL	8
7	1 3/8, 1 3/4, 2, 2 1/2	8
7	3, 3 1/2, 4, 4 1/2	8
7	5	12
8	1 3/8 THRU 4 1/2	8
8	5, 5 1/2	12

# Cushions and Pressure

## Cushions

Sheffer pioneered tapered cushions, designed to provide gradual deceleration and eliminate shock upon entrance of the cushion pistons, have now been considerably improved. The tapered cushion has been married with a fine thread, wide range, adjusting screw. This new combination offers a positive, low-shock deceleration and a method to adjust the cushioning effect for speeds and loads.

The adjusting screw is identified by a tag affixed to the head (or cap) and can be further distinguished by a cross-slot in the head of the screw. It does not project beyond the surface of the head (or cap) through its full range of adjustment so no clearance need be considered on close fit installations. The adjusting screw and the cushion check can be interchanged in the same cylinder end. This flexibility can be important if, after installation, it is discovered that the adjusting screw is inaccessible.

The cushion check, which does not require adjustment, has a single slot in its head. It does not project beyond the surface of the head (or cap). The cushion check plus the tapered cushion piston provides rapid acceleration out of cushioning. There is no spring in the cushion check to fatigue, hence, no worry of mechanical failure.

Cushioning is designed to properly cushion the cylinder and is not intended to cushion large inertia loads. Cushions do not substitute for speed controls or deceleration valves on most installations.

As indicated on page MA-6, the standard positions for ports are 1 and 5. Where possible, the standard positions for cushion adjusting screws will be 2 and 6 and the standard positions for cushion checks will be 4 and 8. With some mounting styles, it is not possible to so locate the adjusting screws and checks. For example, a Trunnion Front Mount has the trunnion pins located in positions 2 and 4 on the head. With the port in position 1, the only side available for both adjusting screw and check is position 3. Since both will then be located on the same side, they will be located off-center. This example would hold true with the TR, CL, FHF and RHF mounts. See **Chart A** for standard positions that will be supplied unless otherwise specified. When requested, other positions can be supplied so long as there is no interference with mounting.

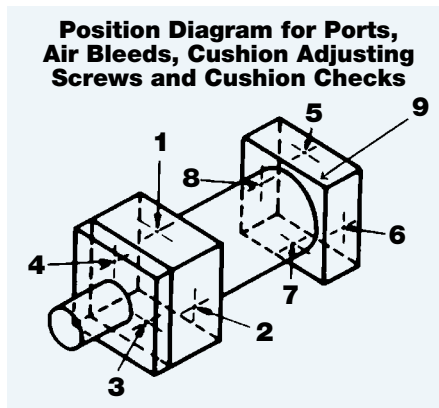
Where access to an adjusting screw or check could be made difficult because of proximity to a mount, the locations of the screws will be slightly off-center. An example of this would be a small bore cylinder with a side lug mount.

Because of space limitations, neither cushion adjusting screws nor cushion ball checks can be put into 1½" and 2", 2½" bore sizes for cushioned front when they are specified with 2:1 rod diameters.

**Chart A**

MOUNT	CUSHION ADJUSTING SCREW	CUSHION CHECK
TF AND FHF	3 and 6	3 and 8
CL	3 and 7	3 and 7
TR AND RHF	2 and 7	4 and 7
ALL OTHER MOUNTS	2 and 6	4 and 8

Standard positions for cushion adjusting screws and cushion checks in relation to port positions by style of mounting.



## Maximum Pressure Ratings

BORE SIZE	PISTON ROD DIAMETER	OPERATING PRESSURE 3:1 SAFETY FACTOR BASED ON YIELD IN PSI	MAX. SHOCK SERVICE 2:1 SAFETY FACTOR BASED ON YIELD IN PSI
1⅛	5/8	3,600	5,400
1½	ALL	2,250	3,375
2	5/8	1,400	2,100
	1, 1⅜	2,450	3,675
2½	5/8, 1	900	1,350
	1⅜, 1¾	1,550	2,325
3¼	ALL	1,400	2,100
4	ALL	925	1,390
5	1, 1⅜, 1¾	675	1,000
	BALANCE	1,075	1,600
6	ALL	800	1,200
7	1⅜, 1¾	625	940
	BALANCE	875	1,300
8	1⅜, 1¾	475	700
	BALANCE	675	1,000

## Specifications

### Cylinder Weight Chart

BORE	1⅛	1½	2	2½	3¼	4	5	6	7	8
ZERO STROKE	3	6	8	11	22	30	45	70	85	100
ADD PER INCH OF STROKE	.25	.35	.6	.9	.9	1.2	1.7	2.5	3	4

NOTE: The above weights are based on an average value for cushioning, rod side, and the various types of mountings for uncrated cylinders to establish approximate shipping weights. Add 10% of cylinder weight to determine estimated weight of crated cylinder.

## Pressure and Shock

The chart below shows the recommended working pressures for MH Series cylinders by bore and rod diameters. Note that the column "Operating Pressure" is based on a 3:1 safety factor. It is felt that this is an adequate safety factor for any well designed hydraulic system where shock conditions have been considered and reduced to an acceptable level.

The "Max. Shock Service" column is based on a 2:1 safety factor and SHOULD NOT be used to determine operating pressures.

All values on the adjacent chart are based on the cylinder as a pressure vessel. Use of the proper mounting style to withstand the thrust generated must be considered.

The following factors in shock loading should be considered:

- Relief valves in the circuit do not protect the components from shock because of the time lag.
- Gauges do not necessarily register shock conditions, either because of their location in the circuit, or the short duration of the shock.
- The two general types of shock loading to be considered are pressure rise caused by quick stop of the flow in the circuit and quick pressure drop. Decompression shock is particularly important in large bore cylinders and can be as destructive as compression shock.

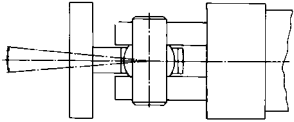
# ► Special Variations

The Sheffer Corporation manufactures many cylinders with variations to meet special customer needs. In addition to those illustrated below, some of the more popular variations are:

- **Cylinders with Boots**
- **Combination Mount Cylinders**
- **Cylinders with Built-In Limit Switch Actuators**
- **Locking Cylinders**
- **Precision Stroke Cylinders**
- **Precision Mount Cylinders**
- **Many More**

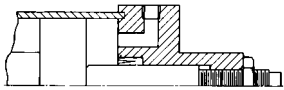
## Spherical Bearings

Pivot mounting brackets and rod eyes can be provided with spherical bearings to compensate for misalignment on both ends of cylinders. Consider also the use of the Sheffer Uni-Lign described in separate Accessories Brochure.



## Adjustable Stroke

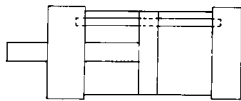
Shown is an integral stroke adjustment (externally adjusted) that is accomplished by the use of a bump rod threaded into the cylinder cap. Seals are incorporated to prevent external leakage and a lock nut is included.



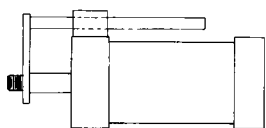
## Non-Rotating Piston Rod

Two methods of providing non-rotating piston rods are employed. The internal rod type (**Figure A**) is generally used since it requires less space and is neater. The type shown in **Figure B** must be used on small bore cylinders where internal space is limited.

**FIGURE A**



**FIGURE B**

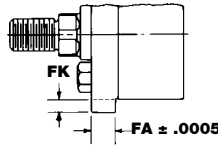


## Stainless Steel Piston Rods

Many applications, especially those subjected to water spray, require the use of stainless steel piston rods. We stock AISI Type 304 hard chrome plated, stainless steel and will furnish that type unless otherwise specified. Type 304 is considered a good, corrosion resistant type of stainless steel, but the minimum expected yield is approximately 35,000 psi and that factor must be considered with respect to operating pressure, column loading, etc.

## Thrust Key

All side mounted cylinders (SF, FB, EL and SL mounts) can be supplied with thrust keys. Thrust keys are available in bore sizes 1 1/8" thru 6". Extending the rod gland retainer, as shown, provides a key which fits into a milled slot in the mounting surface of the machine member. Combined with the mount this key assures that cylinder will not shift in severe service.

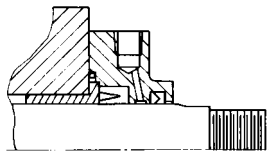


## Thrust Key Bore Sizes

BORE	FA	FK
1 1/8	.3120	3/16
1 1/2	.3120	3/16
2	.3120	3/16
2 1/2	.3120	3/16
3 1/4	.5620	5/16
4	.5620	5/16
5	.5620	5/16
6	.6870	1/8

## Rod Gland Drain Back

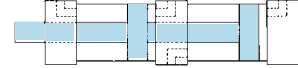
When not even a drop of external leakage can be tolerated, the rod gland drain back provides a signal that the rod seal set has worn to the point of replacement – without the danger of contamination from leakage.



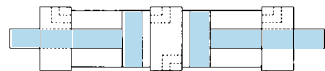
## Tandem Cylinders and Multi-stage Cylinders

The tandem cylinder (**Figure A**) has two pistons connected to a common rod, resulting in twice the force output of a single cylinder. Multi-stage cylinders (**Figure B**) offer multiple, positive strokes by pressurizing one cylinder, the other, or both. Contact the factory for other variations.

**FIGURE A**

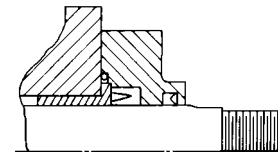


**FIGURE B**



## External Rod Seal

When a cylinder is to be operated under water, provision is made to prevent the water from being drawn into the cylinder at the time of valve shift or pressure differential.

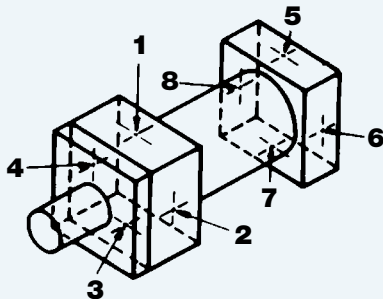


# ► Cushions, Porting and Air Bleeds

## Air Bleeds

An air bleed may be ordered at either or both ends of the cylinder as an option. To provide for maximum bleeding of air from the cylinder, Sheffer places its air bleeds in the tube to bleed air from the tube/head or tube/cap juncture. The air is bled from the cylinder by backing out the straight thread metallic seal plug to allow air to pass by the threads. When air bubbles stop and oil starts to flow, retighten plug. It is recommended that bleeding be done with pressure on the opposite end of the cylinder so that the bleed plug is not subjected to pump pressure when being backed out. Air bleeds should always be positioned at the highest point of the cylinder tube. Please specify positions of air bleeds by position number from the chart. NOTE: Since Sheffer puts air bleeds in the cylinder tube, position can be changed by loosening the tie rods and rotating the tube. Photos and Line Drawings show ports in positions 1 and 5.

**Position Diagram for Ports, Air Bleeds, Cushion Adjusting Screws and Cushion Checks**



## Porting

SAE straight thread Ports, located in positions 1 and 5 (See above) are standard and will be furnished unless otherwise specified. Other types and sizes of ports are available on request, at slight additional cost.

**Port Positions** – Where mounting clearances permit, the ports can be in any of four positions in the head and in the cap at no extra cost. Indicate both port positions desired by position number. If no preference is stated, ports will be furnished in positions 1 and 5. NOTE: The head and cap can be rotated in relation to each other as long as mounting and porting are convenient for installation.

## Strongly Recommended

### S.A.E. Straight Thread Ports –

S.A.E. straight thread O-ring sealed ports are standard. This type of port offers positive seal with full thread engagement. It also eliminates the problem of faulty pipe threads since sealing takes place independently of the thread. No messy pipe dope to bother with or to contaminate the hydraulic system. No wedging, distortion, or breakage due to over-tightening. Alignment and full sealing are both assured since the fittings can be tightened after *lining up*. Straight thread fittings may be reused, indefinitely. NPT ports are available at no extra cost.

**Cushions** – The standard positions for ports are 1 and 5. Where possible, the standard positions for cushion adjusting screws will be 2 and 6 and the standard positions for cushion checks will be 4 and 8. With some mounting styles, it is not possible to so locate the adjusting screws and checks. For example, a Trunnion Front Mount has the trunnion pins located in positions 2 and 4 on the head. With the port in position 1, the only side available for *both* adjusting screw and check is position 3. Since both will then be located on the same side, they will be located off-center. This example would hold true with the TR, CL, FHF and RHF mounts. See **Chart A** for standard positions that will be supplied unless otherwise specified. When requested, other positions can be supplied so long as there is no interference with mounting.

Where access to an adjusting screw or check could be made difficult because of proximity to a mount, the locations of the screws will be slightly off-center. An example of this would be a small bore cylinder with a side lug mount.

Because of space limitations, neither cushion adjusting screws nor cushion ball checks can be put into 1½", 2" and 2½" bore sizes for cushioned front when they are specified with 2:1 rod diameters.

## Special Variations

The Sheffer Corporation manufactures many cylinders with variations to meet customer special needs. Some of the most popular variations are:

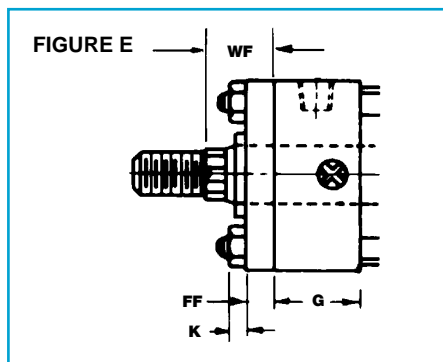
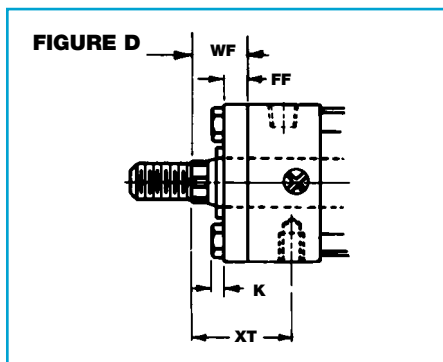
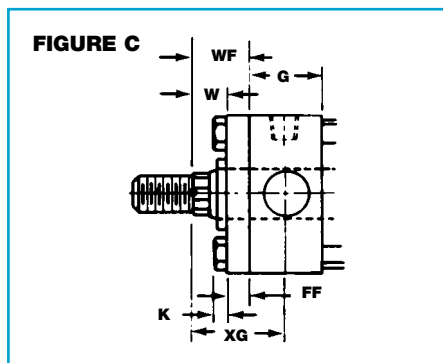
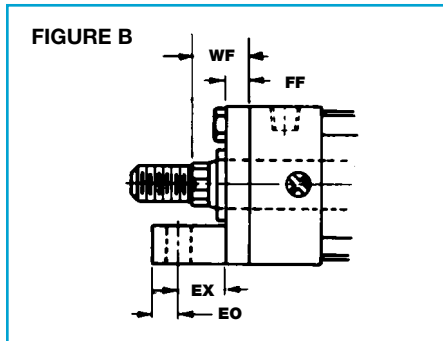
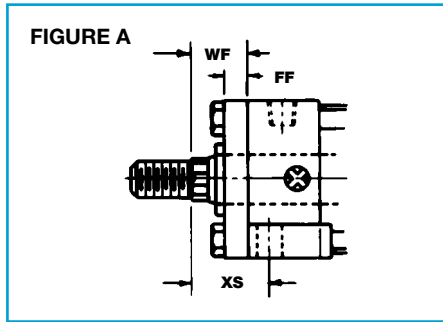
- Cylinders with Boots
- Combination Mount Cylinders
- Precision Stroke Cylinders
- Tandem and Multi-stage Cylinders
- Adjustable Stroke Cylinders
- Non-rotating Rod Cylinders
- Cylinders with Stainless Steel Piston Rods
- Cylinders for Underwater Service
- Many More

Please request a quotation for any special requirement.

## Chart A

**Standard Positions for Cushion Adjusting Screws and Cushion Checks in Relation to Port Positions by Style of Mounting.**

MOUNT	CUSHION ADJUSTING SCREW	CUSHION CHECK
TF AND FHF	3 AND 6	3 AND 8
CL	3 AND 7	3 AND 7
TR AND RHF	2 AND 7	4 AND 7
ALL OTHER MOUNTS	2 AND 6	4 AND 8



### Variations in Construction

There is a construction variance in the 1<sup>1</sup>/<sub>8</sub>" , 1<sup>1</sup>/<sub>2</sub>" , and 2" bore sizes, and the 2<sup>1</sup>/<sub>2</sub>" bore with the 1<sup>3</sup>/<sub>8</sub>" and 1<sup>3</sup>/<sub>4</sub>" rod diameters, and the 3<sup>1</sup>/<sub>4</sub>" bore with a 2" rod diameter. The round rod gland retainer shown on the preceding pages is not employed on these sizes. A square retainer, the same square size as the head is used instead.

**Side Lug (SL) and Centerline Lug (CL) Mounts** – The retainer is held in place with retainer screws that thread into the head. The rod gland can be removed without loosening the tie rods in all sizes. See Fig. A.

**End Lug (EL) Mount** – The bottom two tie rods utilize the lugs as nuts and the top two tie rods have tie rod nuts. The rod gland cannot be removed without loosening the tie rods. See Fig. B.

**Trunnion Front (TF) and Trunnion Rear (TR) Mounts** – The retainer is held in place by retainer screws that thread into the head and the rod gland can be removed without loosening the tie rods in all sizes. See Fig. C.

**Intermediate Trunnion (T) Mount** – The retainer is held in place with tie rod nuts and the rod gland cannot be removed without loosening the tie rods in these sizes. See Fig. C.

**Clevis (C) Mount** – The retainer is held in place with tie rod nuts and the rod gland cannot be removed without loosening the tie rods in 1<sup>1</sup>/<sub>8</sub>" and 1<sup>1</sup>/<sub>2</sub>" bore sizes only.

**Side Flush (SF) Mount** – The retainer is held in place by retainer screws that thread into the head and the rod gland can be removed without loosening the tie rods in all sizes. See Fig. D.

### Trunnion Mounts Note:

Pillow blocks of ample size and rigidity should be provided and should be mounted as close to the head or cap as possible. Bearing should be provided for the full length of the trunnion pin.

All trunnion cylinders need provision on both ends for pivoting in one plane. Alignment in the other direction is essential to avoid excessive side loading. Where two-direction pivoting is necessary, consult with our distributor for specific recommendations. Do not use spherical bearing Pillow Blocks.

### End Lug Note:

When specifying an End Lug mount, carefully check the distance between the rod end and the lug to determine sufficient clearance for the rod end attachment. It may be necessary to add extra plain rod extension to move the threaded rod end out beyond the lug.

### Side Lug Note:

When specifying a Side Lug mount with the ports on the side (port positions 2, 4, 6 or 8), be sure that there will be enough clearance between the port fitting and the lug to insert a bolt or cap screw into the

lug. In small bore sizes, it may be necessary to employ a pipe nipple to easily pipe the port.

### Variations in Construction – Flange Mount Cylinders

There is a construction variance in some bore and rod size combinations where it is not possible to utilize the round, cap screwed, rod gland retainer. Affected dimensions can be determined by Fig. E.

### Front Flange (FF) and Front Flange Extra (FFX) Mounts

On the bore and rod combinations affected, the tie rods thread into the flange and the flange serves as the rod gland retainer. Tie Rod nuts are employed on the cap end. The rod gland cannot be removed without loosening the tie rods in these sizes. See chart on page MH-10 for combinations affected.

### Front Head Flange (FHF) Mount

On the bore and rod combinations affected, the retainer is rectangular, the same size as the head, and the tie rods thread into it. Tie rod nuts are employed on the cap end. The rod gland cannot be removed without loosening the tie rods. See chart on page MH-10 for combinations affected. Mounting bolts should be sized to clear through both the head (G dim.) and the rectangular retainer thickness (FF dim.).

### Rear Flange (RF), Rear Flange Extra (RFX) and Rear Head Flange (RHF) Mounts

On the bore and rod combinations affected, a square retainer, the same square size as the head, is employed. The retainer is cleared for the tie rods, and tie rod nuts secure it. The rod gland cannot be removed without loosening the tie rods. The combinations affected are shown in the chart on page MH-12.

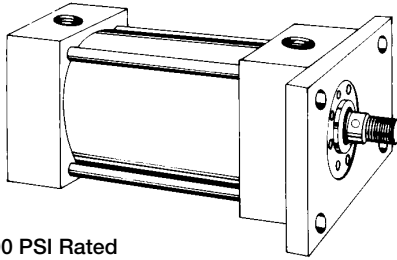
### Side Flush Note: Thread Depth and Side Flush Mounting Availability Chart

BORE	ROD DIA.	THREAD DEPTH
1 <sup>1</sup> / <sub>8</sub>	5/8	3/8
1 <sup>1</sup> / <sub>2</sub>	5/8	3/8
2	1	5/16
2 <sup>1</sup> / <sub>2</sub>	5/8, 1, 1 <sup>3</sup> / <sub>8</sub>	7/16
	1 <sup>3</sup> / <sub>4</sub>	5/8
3 <sup>1</sup> / <sub>4</sub>	1, 1 <sup>3</sup> / <sub>8</sub> , 1 <sup>3</sup> / <sub>4</sub>	7/16
	2	3/4
4	1, 1 <sup>3</sup> / <sub>8</sub> , 1 <sup>3</sup> / <sub>4</sub> , 2	1/2
	2 <sup>1</sup> / <sub>2</sub>	3/4
5	1, 1 <sup>3</sup> / <sub>8</sub> , 1 <sup>3</sup> / <sub>4</sub> , 2, 2 <sup>1</sup> / <sub>2</sub>	15/16
	3	3/4
	3 <sup>1</sup> / <sub>2</sub>	1 <sup>1</sup> / <sub>8</sub>
6	1 <sup>3</sup> / <sub>8</sub> , 1 <sup>3</sup> / <sub>4</sub> , 2, 2 <sup>1</sup> / <sub>2</sub> , 3, 3 <sup>1</sup> / <sub>2</sub>	1
	4	1 <sup>1</sup> / <sub>8</sub>
7	1 <sup>3</sup> / <sub>8</sub> , 1 <sup>3</sup> / <sub>4</sub> , 2, 2 <sup>1</sup> / <sub>2</sub> , 3, 3 <sup>1</sup> / <sub>2</sub> , 4, 4 <sup>1</sup> / <sub>2</sub>	1 <sup>1</sup> / <sub>8</sub>
	5	1
8	ALL	1 <sup>1</sup> / <sub>8</sub>

NOTE: Side flush mounting is available with usable thread depths shown above.

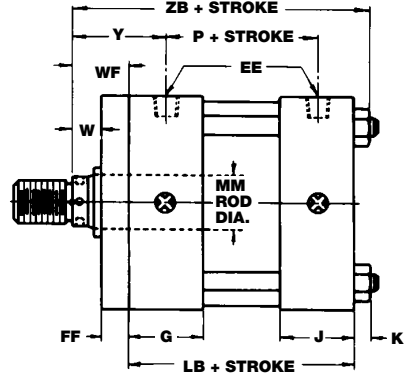
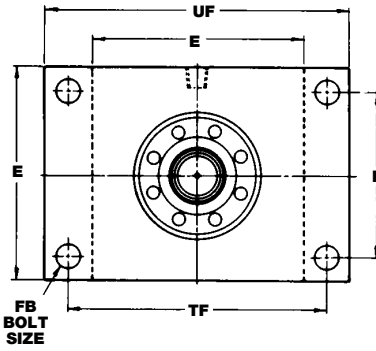


### FRONT FLANGE MOUNT STYLE FF (MF1)\*

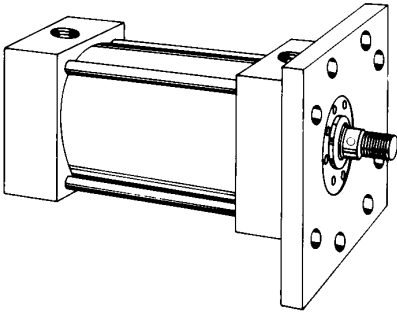


1000 PSI Rated

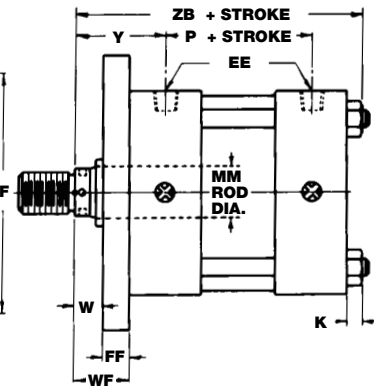
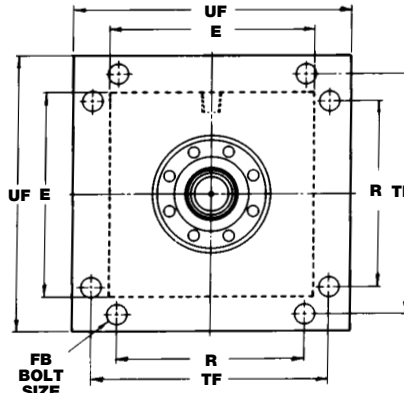
Note: 1 1/8" through 6" bore only.



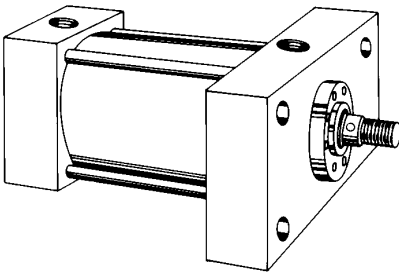
### FRONT FLANGE MOUNT EXTRA SIZE STYLE FFX (MF5)\*



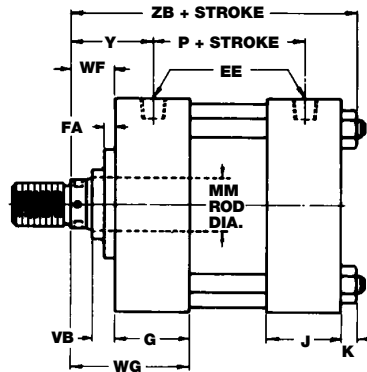
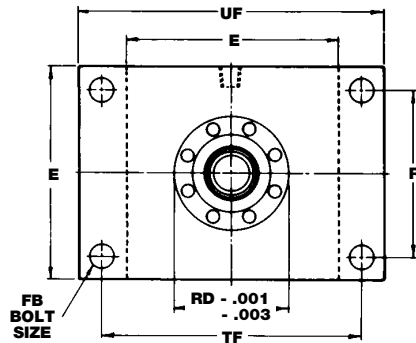
Note: 1 1/8" through 6" bore only.



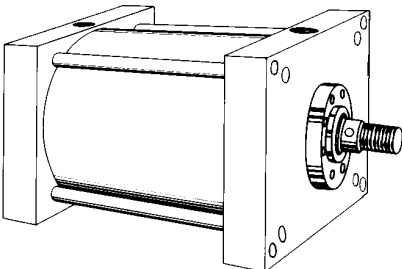
### FRONT HEAD FLANGE MOUNT STYLE FHF (ME5)\*



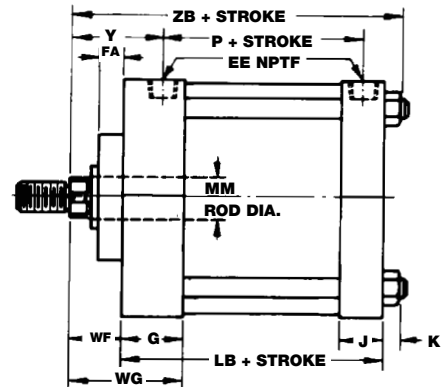
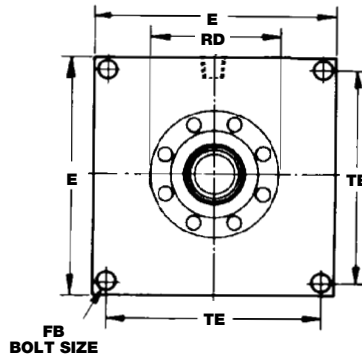
Note: 1 1/8" through 6" bore only.



### FRONT HEAD MOUNT STYLE FH (ME3)\*



Note: 7" through 8" bore only.



\*ANSI/B93.1-1964 Mounting Style Designation.

### IMPORTANT NOTE

#### Pressure Restrictions

Rectangular flange mount cylinders (style FF) are not recommended for use at the full operating pressure ratings shown in separate Engineering Brochure. Some methods of employing a cylinder with a rectangular mount can produce a condition where flexure of the flange can result in fatigue failure of the mounting bolts or flange retainer fasteners. If pressures in excess of those shown in the chart below are anticipated, a more rigid mount such as an FFX, RFX, FHF, or RHF should be selected. Whenever there is doubt, select a FHF or RHF mount.

### Recommended Maximum Pressures for Rectangular Flange Mount Cylinders

BORE	ROD DIAMETER	MAXIMUM PRESSURE IN PSI
1 1/8	5/8	1000
1 1/2	ALL	750
2	5/8	650
	BALANCE	500
2 1/2	5/8, 1	400
	BALANCE	300
3 1/4	1, 1 3/8	650
	BALANCE	400
4	1, 1 3/8, 1 3/4	500
	BALANCE	350
5	1, 1 3/8, 1 3/4	350
	BALANCE	200
6	1 3/8, 1 3/4, 2	400
	BALANCE	250

### IMPORTANT- Construction Variances

For information on construction variance on **Front Flange (FF), Front Flange Extra (FFX) and Front Head Flange (FHF) Mounts**, refer to page MH-8.

### Construction Variances

An X Indicates Sizes Affected

BORE	ROD DIA.	FF FFX	FHF
1 1/8	5/8	X	X
1 1/2	5/8	X	X
2	5/8	X	X
	1	X	X
	1 3/8	X	X
2 1/2	1 3/8	X	X
	1 3/4	X	X
3 1/4	2	X	X
4	2 1/2	X	—
5	3 1/2	X	—

### Front Flange Dimensions

BORE	ROD DIA.	FA	RD	VB	W	WF	WG	Y	ZB*
1 1/8	5/8	—	—	—	5/8	1 1/8	2 1/4	1 23/32	4 5/8*
1 1/2	5/8	—	—	—	5/8	1	2 1/2	1 15/16	4 27/32*
	1	—	—	—	1	1 3/8	2 7/8	2 5/16	5 7/32*
2	5/8	—	—	—	5/8	1	2 1/2	1 15/16	4 7/8*
	1	—	—	—	1	1 3/8	2 7/8	2 5/16	5 1/4*
	1 3/8	—	—	—	1 1/4	1 5/8	3 1/8	2 9/16	5 1/2*
2 1/2	5/8	1 1/32	2.187	3/4	5/8	1	2 1/2	1 15/16	5*
	1	1 1/32	2.375	7/8	1	1 3/8	2 7/8	2 5/16	5 3/8*
	1 3/8	—	—	—	1 1/4	1 5/8	3 1/8	2 9/16	5 5/8*
	1 3/4	—	—	—	1 3/8	1 7/8	3 3/8	2 13/16	5 7/8*
3 1/4	1	1 1/32	2.375	7/8	3/4	1 3/8	3 1/8	2 7/16	5 15/16*
	1 3/8	1 1/32	2.875	1	1	1 5/8	3 3/8	2 11/16	6 3/16*
	1 3/4	1 1/32	3.250	1 1/8	1 1/4	1 7/8	3 5/8	2 15/16	6 7/16*
	2	—	—	—	1 3/8	2	3 3/4	3 1/16	6 9/16*
4	1	1 1/32	2.375	7/8	3/4	1 3/8	3 1/8	2 7/16	5 15/16*
	1 3/8	1 1/32	2.875	1	1	1 5/8	3 3/8	2 11/16	6 3/16*
	1 3/4	1 1/32	3.250	1 1/8	1 1/4	1 7/8	3 5/8	2 15/16	6 7/16*
	2	1 1/32	3.562	1 1/8	1 3/8	2	3 3/4	3 1/16	6 9/16*
	2 1/2	1 1/32	4.000	1 1/4	1 5/8	2 1/4	4	3 5/16	6 13/16*
5	1	1 1/32	2.375	7/8	3/4	1 3/8	3 1/8	2 7/16	6 5/16*
	1 3/8	1 1/32	2.875	1	1	1 5/8	3 3/8	2 11/16	6 9/16*
	1 3/4	1 1/32	3.250	1 1/8	1 1/4	1 7/8	3 5/8	2 15/16	6 13/16*
	2	1 1/32	3.562	1 1/8	1 3/8	2	3 3/4	3 1/16	6 15/16*
	2 1/2	1 1/32	4.000	1 1/4	1 5/8	2 1/4	4	3 5/16	7 3/16*
6	3	1 1/32	4.750	1 1/4	1 5/8	2 1/4	4	3 5/16	7 3/16*
	3 1/2	2 3/32	5.187	1 1/4	1 5/8	2 1/4	4	3 5/16	7 3/16*
	1 3/8	1 1/32	2.875	1	7/8	1 5/8	3 3/8	2 13/16	7 1/16*
	1 3/4	1 1/32	3.250	1 1/8	1 1/8	1 7/8	3 7/8	3 1/16	7 5/16*
	2	1 1/32	3.562	1 1/8	1 1/4	2	4	3 3/16	7 7/16*
7	2 1/2	1 1/32	4.000	1 1/4	1 1/2	2 1/4	4 1/4	3 5/16	7 11/16*
	3	1 1/32	4.750	1 1/4	1 1/2	2 1/4	4 1/4	3 5/16	7 11/16*
	3 1/2	2 3/32	5.187	1 1/4	1 1/2	2 1/4	4 1/4	3 5/16	7 11/16*
	4	2 3/32	5.750	1 1/4	1 1/2	2 1/4	4 1/4	3 5/16	7 11/16*
	4 1/2	3/4	6.250	1 1/4	1 1/2	2 1/4	4 1/4	3 5/16	7 11/16*
8	5	3/4	6.750	1 1/4	1 1/2	2 1/4	4 1/4	3 5/16	7 11/16*
	1 3/8	1 1/32	2.875	1	—	1 5/8	3 5/8	2 13/16	7 5/16*
	1 3/4	1 1/32	3.250	1 1/8	—	1 7/8	3 7/8	3 1/16	7 9/16*
	2	1 1/32	3.562	1 1/8	—	2	4	3 3/16	7 11/16*
	2 1/2	1 1/32	4.000	1 1/4	—	2 1/4	4 1/4	3 7/16	7 15/16*

\*Be sure to add stroke to this dimension.

### Front Flange Dimensions

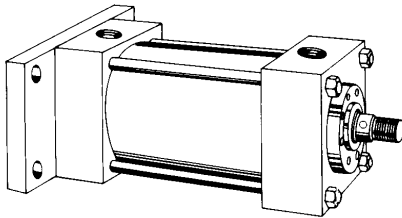
BORE	E	EE NPT†	EE SAE	FB**	FF	G	J	K	LB*	P*	R	TE	TF	UF
1 1/8	1 3/4	1/4	-6	1/4	1/2	1 1/8	1	1/4	3 1/4*	2 3/16*	1.19	—	2 3/8	3
1 1/2	2	3/8	-6	1/4	3/8	1 1/2	1	7/32	3 5/8*	2 1/4*	1.43	—	2 3/4	3 3/8
2	2 1/2	3/8	-6	5/16	3/8	1 1/2	1	1/4	3 5/8*	2 1/4*	1.84	—	3 3/8	4 1/8
2 1/2	3	3/8	-6	5/16	3/8	1 1/2	1	1/4	3 3/4*	2 3/8*	2.19	—	3 7/8	4 5/8
3 1/4	3 3/4	1/2	-10	3/8	5/8	1 3/4	1 1/4	5/16	4 1/4*	2 5/8*	2.76	—	4 11/16	5 1/2
4	4 1/2	1/2	-10	3/8	5/8	1 3/4	1 1/4	5/16	4 1/4*	2 5/8*	3.32	—	5 7/16	6 1/4
5	5 1/2	1/2	-10	1/2	5/8	1 3/4	1 1/4	7/16	4 1/2*	2 7/8*	4.10	—	6 5/8	7 5/8
6	6 1/2	3/4	-12	1/2	3/4	2	1 1/2	7/16	5*	3 1/8*	4.88	—	7 5/8	8 5/8
7	7 1/2	3/4	-12	1/2	—	2	1 1/2	9/16	5 1/8*	3 1/4*	5.73	6.75	—	—
8	8 1/2	3/4	-12	5/8	—	2	1 1/2	9/16	5 1/8*	3 1/4*	6.44	7.57	—	—

\*Be sure to add stroke to this dimension.

\*\*Clearance holes for indicated bolt size.

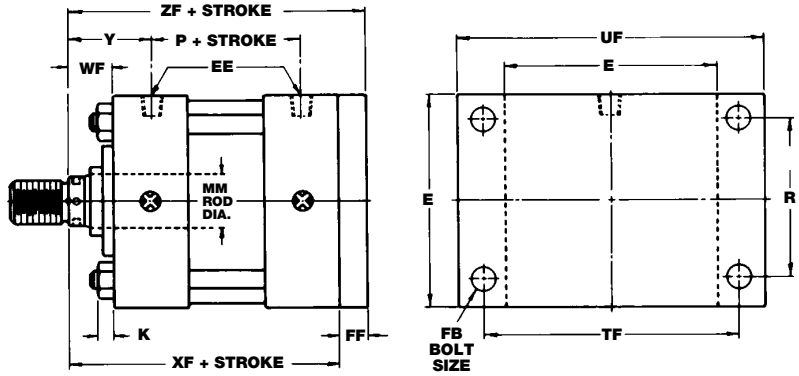
†Alternate port at no extra charge. SAE port is standard.

### REAR FLANGE MOUNT STYLE RF (MF2)\*

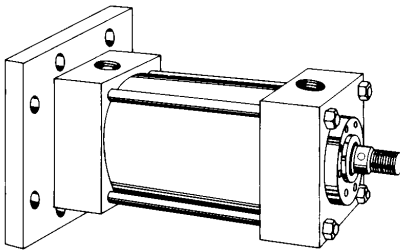


1000 PSI Rated

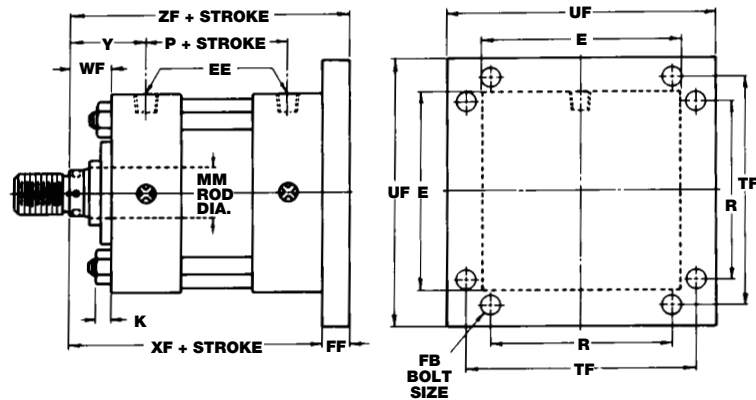
Note: 1 1/8" through 6" bore only.



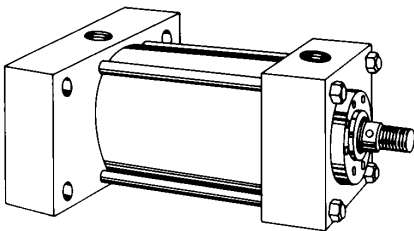
### REAR FLANGE MOUNT EXTRA SIZE STYLE RFX (MF6)\*



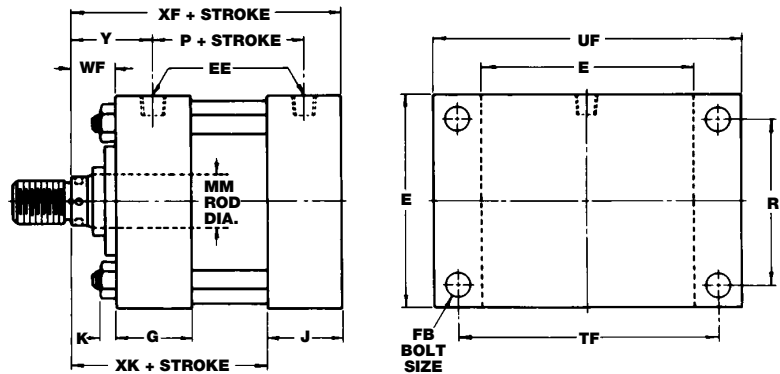
Note: 1 1/8" through 6" bore only.



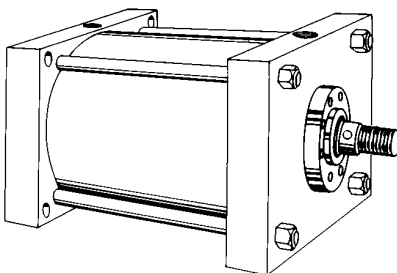
### REAR HEAD FLANGE MOUNT STYLE RHF (ME6)\*



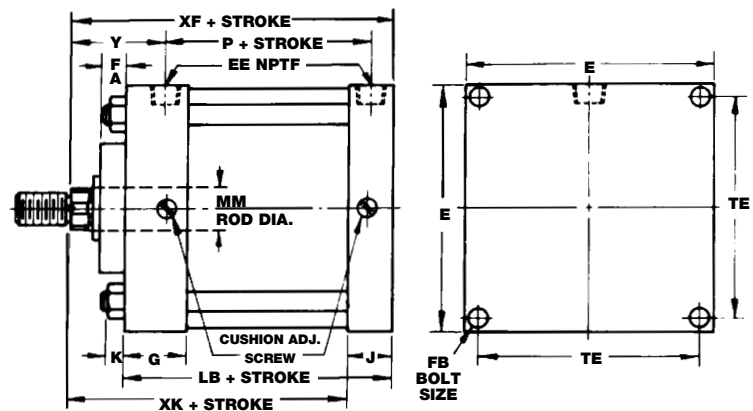
Note: 1 1/8" through 6" bore only.



### REAR HEAD MOUNT STYLE RH (ME4)\*



Note: 7" through 8" bore only.



\*ANSI/B93.1-1964 Mounting Style Designation.

### IMPORTANT NOTE

#### Pressure Restrictions

Rectangular flange mount cylinders (style RF) are not recommended for use at the full operating pressure ratings shown in separate Engineering Brochure. Some methods of employing a cylinder with a rectangular mount can produce a condition where flexure of the flange can result in fatigue failure of the mounting bolts or flange retainer fasteners. If pressures in excess of those shown in the chart below are anticipated, a more rigid mount such as an RFX or RHF should be selected. Whenever there is doubt, select an RHF mount.

### Recommended Maximum Pressures for Rectangular Flange Mount Cylinders

BORE	MAXIMUM PRESSURE IN PSI
1 1/8	1000
1 1/2	750
2	650
2 1/2	400
3 1/4	650
4	500
5	350
6	400

### IMPORTANT - Construction Variances

For information on construction variance on **Rear Flange (RF), Rear Flange Extra (RFX) and Rear Head Flange (RHF) Mounts**, refer to page MH-7.

### Construction Variances An X Indicates Sizes Affected

BORE	ROD DIA.	RF, RFX, RHF
1 1/8	5/8	X
1 1/2	5/8	X
2	5/8	X
	1	X
2 1/2	1 3/8	X
	1 3/8	X
3 1/4	1 3/4	X
	2	X
4	2 1/2	—
5	3 1/2	—

### Rear Flange Dimensions

BORE	ROD DIA.	FA	WF	XF*	XK*	Y	ZF*
1 1/8	5/8	—	1 1/8	4 3/8*	3 3/8*	1 23/32	4 3/4*
	1 1/2	—	1	4 5/8*	3 5/8*	1 15/16	5*
2	1	—	1 3/8	5*	4*	2 5/16	5 3/8*
	5/8	—	1	4 5/8*	3 5/8*	1 15/16	5*
2 1/2	1	—	1 3/8	5*	4*	2 5/16	5 3/8*
	1 3/8	—	1 5/8	5 1/4*	4 1/4*	2 9/16	5 5/8*
	1 3/8	11/32	1	4 3/4*	3 3/4*	1 15/16	5 1/8*
3 1/4	1	—	1 3/8	5 1/8*	4 1/8*	2 5/16	5 1/2*
	1 3/8	—	1 5/8	5 3/8*	4 3/8*	2 9/16	5 3/4*
	1 3/4	—	1 7/8	5 5/8*	4 5/8*	2 13/16	6*
4	1	11/32	1 3/8	5 5/8*	4 3/8*	2 7/16	6 1/4*
	1 3/8	—	1 5/8	5 7/8*	4 5/8*	2 11/16	6 1/2*
	1 3/4	—	1 7/8	6 1/8*	4 7/8*	2 15/16	6 3/4*
	2	—	2	6 1/4*	5*	3 1/16	6 7/8*
5	2 1/2	19/32	2 1/4	6 1/2*	5 1/4*	3 5/16	7 1/8*
	1	11/32	1 3/8	5 7/8*	4 3/8*	2 7/16	6 1/4*
	1 3/8	—	1 5/8	5 7/8*	4 5/8*	2 11/16	6 1/2*
	1 3/4	—	1 7/8	6 1/8*	4 7/8*	2 15/16	6 3/4*
	2	—	2	6 1/4*	5*	3 1/16	6 7/8*
6	2 1/2	19/32	2 1/4	6 1/2*	5 1/4*	3 5/16	7 1/8*
	1	11/32	1 3/8	5 7/8*	4 3/8*	2 7/16	6 1/4*
	1 3/8	—	1 5/8	6 1/8*	4 7/8*	2 11/16	6 3/4*
	1 3/4	—	1 7/8	6 3/8*	5 1/8*	2 15/16	7*
	2	—	2	6 1/2*	5 1/4*	3 1/16	7 1/8*
7	2 1/2	19/32	2 1/4	6 3/4*	5 3/8*	3 5/16	7 3/8*
	3	—	2 1/4	6 3/4*	5 3/8*	3 5/16	7 3/8*
	3 1/2	—	2 1/4	6 3/4*	5 3/8*	3 5/16	7 3/8*
	1 3/8	—	1 5/8	6 5/8*	5 1/8*	2 13/16	7 3/8*
	1 3/4	—	1 7/8	6 7/8*	5 3/8*	3 1/16	7 5/8*
8	2	—	2	7*	5 1/2*	3 3/16	7 3/4*
	2 1/2	—	2 1/4	7 1/4*	5 3/4*	3 7/16	8*
	3	—	2 1/4	7 1/4*	5 3/4*	3 7/16	8*
	3 1/2	—	2 1/4	7 1/4*	5 3/4*	3 7/16	8*
	4	—	2 1/4	7 1/4*	5 3/4*	3 7/16	8*
8	1 3/8	—	1 5/8	6 3/4*	5 1/4*	2 13/16	—
	1 3/4	—	1 7/8	7*	5 1/2*	3 1/16	—
	2	—	2	7 1/8*	5 5/8*	3 3/16	—
	2 1/2	—	2 1/4	7 3/8*	5 7/8*	3 5/16	—
	3	—	2 1/4	7 3/8*	5 7/8*	3 7/16	—
8	3 1/2	—	2 1/4	7 3/8*	5 7/8*	3 7/16	—
	4	—	2 1/4	7 3/8*	5 7/8*	3 7/16	—
	4 1/2	—	2 1/4	7 3/8*	5 7/8*	3 7/16	—
	5	—	2 1/4	7 3/8*	5 7/8*	3 7/16	—
	5 1/2	—	2 1/4	7 3/8*	5 7/8*	3 7/16	—

\*Be sure to add stroke to this dimension.

### Rear Flange Dimensions

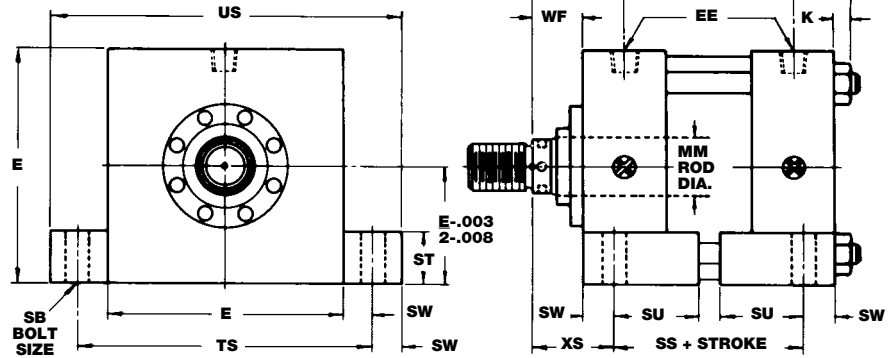
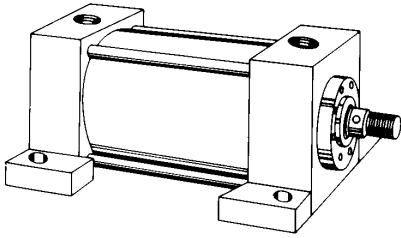
BORE	E	EE NPT†	EE SAE	FB**	F	G	J	K	LB*	P*	R	TE	TF	UF
1 1/8	1 3/4	1/4	-6	1/4	3/8	1 1/8	1	1/4	3 1/4*	2 3/16*	1.19	—	2 3/8	3
1 1/2	2	3/8	-6	1/4	3/8	1 1/2	1	7/32	3 5/8*	2 1/4*	1.43	—	2 3/4	3 3/8
2	2 1/2	3/8	-6	5/16	3/8	1 1/2	1	1/4	3 5/8*	2 1/4*	1.84	—	3 3/8	4 1/8
2 1/2	3	3/8	-6	5/16	3/8	1 1/2	1	1/4	3 3/4*	2 3/8*	2.19	—	3 7/8	4 5/8
3 1/4	3 3/4	1/2	-10	3/8	5/8	1 3/4	1 1/4	5/16	4 1/4*	2 5/8*	2.76	—	4 11/16	5 1/2
4	4 1/2	1/2	-10	3/8	5/8	1 3/4	1 1/4	5/16	4 1/4*	2 5/8*	3.32	—	5 7/16	6 1/4
5	5 1/2	1/2	-10	1/2	5/8	1 3/4	1 1/4	7/16	4 1/2*	2 7/8*	4.10	—	6 5/8	7 5/8
6	6 1/2	3/4	-12	1/2	3/4	2	1 1/2	7/16	5*	3 1/8*	4.88	—	7 5/8	8 5/8
7	7 1/2	3/4	-12	1/2	—	2	1 1/2	9/16	5 1/8*	3 1/4*	—	6.75	—	—
8	8 1/2	3/4	-12	5/8	—	2	1 1/2	9/16	5 1/8*	3 1/4*	—	7.57	—	—

\*Be sure to add stroke to this dimension.

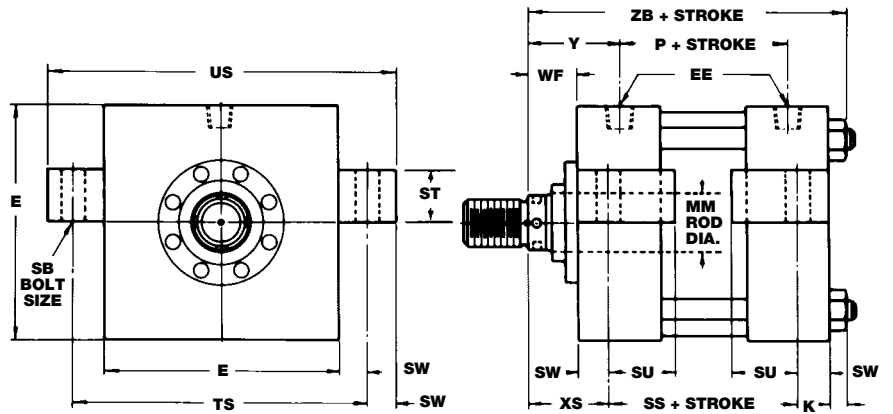
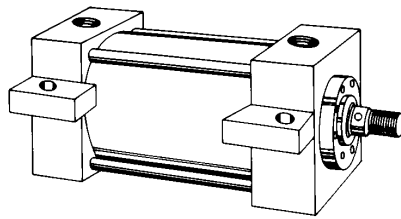
\*\*Clearance holes for indicated bolt size.

†Alternate port at no extra charge. SAE port is standard.

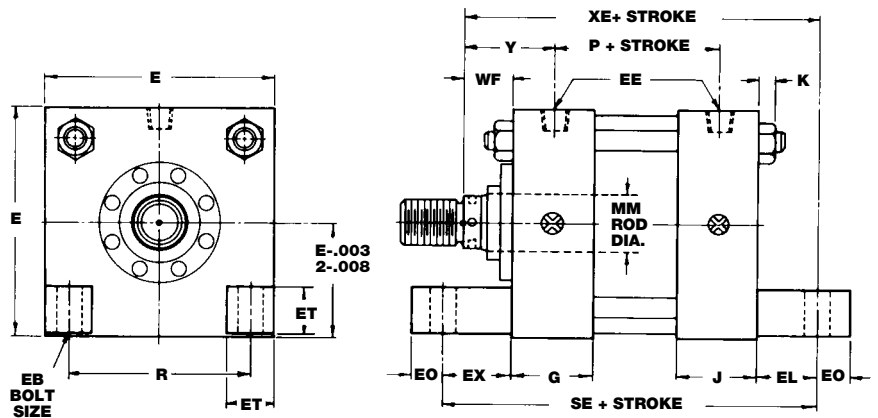
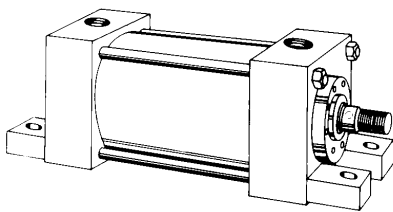
### SIDE LUG MOUNT STYLE SL (MS2)\*



### CENTER LINE LUG MOUNT STYLE CL (MS3)\*



### END LUG MOUNT STYLE EL (MS7)\*



\*ANSI/B93.1-1964 Mounting Style Designation.

### CAUTION

When specifying a Side Lug Mount with ports on the side (port positions 2, 4, 6 or 8), be sure that there will be enough clearance between the port fitting and the lug to insert a bolt or capscrew into the lug. In small bore sizes, it may even be necessary to employ a pipe nipple to easily pipe the port.

When specifying an End Lug Mount, carefully check the distance between the rod end and the lug to determine sufficient clearance for rod end attachment. It may be necessary to add extra plain rod extension to move the threaded rod end out beyond the lug. When using a rod eye or rod clevis, we recommend the extra plain rod extensions in the chart below be specified.

Consult separate Accessories Brochure for information concerning the selection and application of lug mount cylinders.

See separate Engineering Brochure for long stroke cylinder data. Selection of piston rod diameter can be determined from information in separate Engineering Brochure.

### IMPORTANT - Construction Variances

For information on construction variance on **Side Lug (SL), Center-line Lug (CL) and End Lug (EL) Mounts**, refer to page MH-7.

### Lug Dimensions

BORE	ROD DIA.	EX	WF	XE*	XS	Y	ZB*
1 1/8	5/8	3/4	1 1/8	5 1/8*	1 3/8	1 23/32	4 5/8*
1 1/2	5/8	3/4	1	5 3/8*	1 3/8	1 15/16	4 27/32*
	1	3/4	1 3/8	5 3/4*	1 3/4	2 5/16	5 7/32*
2	5/8	15/16	1	5 9/16*	1 3/8	1 15/16	4 7/8*
	1	15/16	1 3/8	5 15/16*	1 3/4	2 5/16	5 1/4*
	1 3/8	15/16	1 5/8	6 3/16*	2	2 9/16	5 1/2*
2 1/2	5/8	1 7/16	1	5 13/16*	1 3/8	1 15/16	5*
	1	1 7/16	1 3/8	6 3/16*	1 3/4	2 5/16	5 3/8*
	1 3/8	1 1/16	1 5/8	6 7/16*	2	2 9/16	5 5/8*
	1 3/4	1 1/16	1 7/8	6 1 1/16*	2 1/4	2 13/16	5 7/8*
3 1/4	1	1 1/2	1 3/8	6 1/2*	1 7/8	2 7/16	5 15/16*
	1 3/8	1 1/2	1 5/8	6 3/4*	2 1/8	2 1 1/16	6 3/16*
	1 3/4	1 1/2	1 7/8	7*	2 3/8	2 15/16	6 7/16*
	2	7/8	2	7 1/8*	2 1/2	3 1/16	6 9/16*
4	1	1 5/8	1 3/8	6 5/8*	1 7/8	2 7/16	5 15/16*
	1 3/8	1 5/8	1 5/8	6 7/8*	2 1/8	2 1 1/16	6 3/16*
	1 3/4	1 5/8	1 7/8	7 1/8*	2 3/8	2 15/16	6 7/16*
	2	1 5/8	2	7 1/4*	2 1/2	3 1/16	6 9/16*
	2 1/2	1 5/8	2 1/4	7 1/2*	2 3/4	3 5/16	6 13/16*
5	1	1 11/16	1 3/8	6 15/16*	2 1/16	2 7/16	6 5/16*
	1 3/8	1 11/16	1 5/8	7 3/16*	2 5/16	2 1 1/16	6 9/16*
	1 3/4	1 11/16	1 7/8	7 1/16*	2 9/16	2 15/16	6 13/16*
	2	1 11/16	2	7 9/16*	2 11/16	3 1/16	6 15/16*
	2 1/2	1 11/16	2 1/4	7 13/16*	2 15/16	3 5/16	7 3/16*
	3	1 11/16	2 1/4	7 13/16*	2 15/16	3 5/16	7 3/16*
6	1 3/8	1 3/4	1 5/8	7 5/8*	2 5/16	2 13/16	7 1/16*
	1 3/4	1 3/4	1 7/8	7 7/8*	2 9/16	3 1/16	7 5/16*
	2	1 3/4	2	8*	2 11/16	3 3/16	7 7/16*
	2 1/2	1 3/4	2 1/4	8 1/4*	2 15/16	3 7/16	7 11/16*
	3	1 3/4	2 1/4	8 1/4*	2 15/16	3 7/16	7 11/16*
	3 1/2	1 3/4	2 1/4	8 1/4*	2 15/16	3 7/16	7 11/16*
7	1 3/8	1 1/8	1 5/8	7 7/8*	2 5/16	2 13/16	7 5/16*
	1 3/4	1 1/8	1 7/8	8 1/8*	2 9/16	3 1/16	7 9/16*
	2	1 1/8	2	8 1/4*	2 11/16	3 3/16	7 11/16*
	2 1/2	1 1/8	2 1/4	8 1/2*	2 15/16	3 7/16	7 15/16*
	3	1 1/8	2 1/4	8 1/2*	2 15/16	3 7/16	7 15/16*
	3 1/2	1 1/8	2 1/4	8 1/2*	2 15/16	3 7/16	7 15/16*
	4	1 1/8	2 1/4	8 1/2*	2 15/16	3 7/16	7 15/16*
8	4 1/2	1 1/8	2 1/4	8 1/2*	2 15/16	3 7/16	7 15/16*
	5	1 1/8	2 1/4	8 1/2*	2 15/16	3 7/16	7 15/16*
	5 1/2	1 1/8	2 1/4	8 1/2*	2 15/16	3 7/16	7 15/16*

\*Be sure to add stroke to this dimension.

### Lug Dimensions

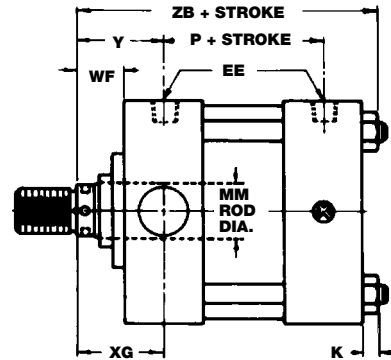
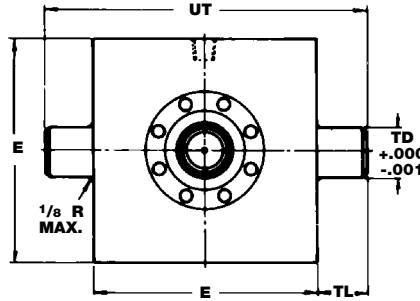
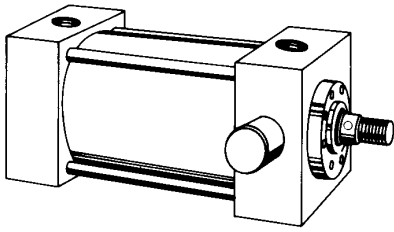
BORE	E	EB**	EE NPT†	EE SAE	EL	EO	ET	G	J	K	P*	R	SB**	SE*	SS*	ST	SU	SW	TS	US
1 1/8	1 3/4	1/4	1/4	-6	3/4	1/4	1/2	1 1/8	1	1/4	2 3/16*	1.19	5/16	5 1/4*	2 5/8*	1/2	1 5/16	3/8	2 1/2	3 1/4
1 1/2	2	1/4	3/8	-6	3/4	1/4	1/2	1 1/2	1	7/32	2 1/4*	1.43	3/8	5 1/2*	2 7/8*	1/2	1 5/16	3/8	2 3/4	3 1/2
2	2 1/2	5/16	3/8	-6	1 5/16	5/16	9/16	1 1/2	1	1/4	2 1/4*	1.84	3/8	5 7/8*	2 7/8*	1/2	1 5/16	3/8	3 1/4	4
2 1/2	3	5/16	3/8	-6	1 1/16	5/16	1 1/16	1 1/2	1	1/4	2 3/8*	2.19	3/8	6 1/4*	3*	1/2	1 5/16	3/8	3 3/4	4 1/2
3 1/4	3 3/4	3/8	1/2	-10	7/8	3/8	7/8	1 3/4	1 1/4	5/16	2 5/8*	2.76	1/2	6 5/8*	3 1/4*	3/4	1 1/4	1/2	4 3/4	5 3/4
4	4 1/2	3/8	1/2	-10	1	3/8	1 1/16	1 3/4	1 1/4	5/16	2 5/8*	3.32	1/2	6 7/8*	3 1/4*	3/4	1 1/4	1/2	5 1/2	6 1/2
5	5 1/2	1/2	1/2	-10	1 1/16	1/2	1 5/16	1 3/4	1 1/4	7/16	2 7/8*	4.10	3/4	7 1/4*	3 1/8*	1	1 9/16	1 1/16	6 7/8	8 1/4
6	6 1/2	1/2	3/4	-12	1	1/2	1 1/2	2	1 1/2	7/16	3 1/8*	4.88	3/4	7 3/4*	3 5/8*	1	1 9/16	1 1/16	7 7/8	9 1/4
7	7 1/2	5/8	3/4	-12	1 1/8	5/8	1 5/8	2	1 1/2	9/16	3 1/4*	5.73	3/4	7 3/8*	3 3/4*	1	1 9/16	1 1/16	8 7/8	10 1/4
8	8 1/2	5/8	3/4	-12	1 1/8	5/8	2	2	1 1/2	9/16	3 1/4*	6.44	3/4	7 3/8*	3 3/4*	1	1 9/16	1 1/16	9 7/8	11 1/4

\*Be sure to add stroke to this dimension.

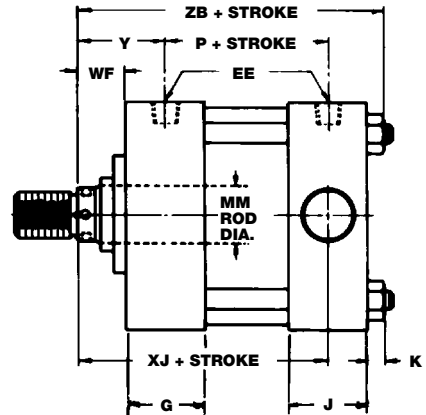
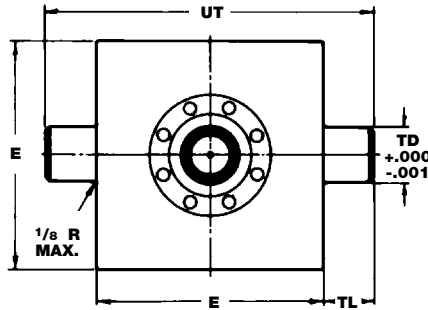
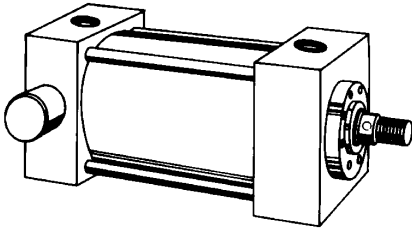
\*\*Clearance holes for indicated bolt size.

†Alternate port at no extra charge. SAE port is standard.

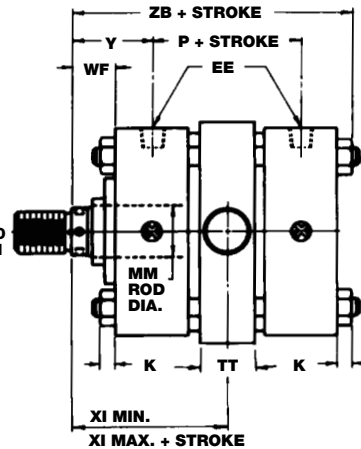
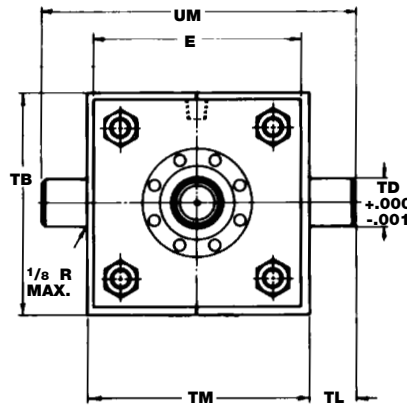
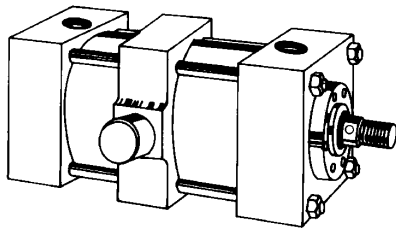
## TRUNNION FRONT MOUNT STYLE TF (MT1)\*



## TRUNNION REAR MOUNT STYLE TR (MT2)\*



## TRUNNION MOUNT STYLE T (MT4)\*



(Intermediate - Between Heads)  
Position NOT adjustable.

\*ANSI/B93.1-1964 Mounting Style Designation.

### CAUTION

Sheffer trunnion pins are an integral part of the head (TF Mount), the cap (TR Mount), or the ring on the intermediate trunnion mount (T). Even though machining the pins as an integral part is the strongest, and most fatigue-resistant method, some attention should be given to proper mounting of trunnion cylinders.

Pillow blocks of ample size and rigidity should be provided and should be mounted as close to the head or cap as possible. Bearing should be provided for the full length of the trunnion pin. Pins are designed for shear loads only, not bending loads. Lubrication should be provided to the pins.

All trunnion cylinders need provision on both ends for pivoting in one direction. Alignment in the other direction is essential in order to avoid excessive side loading. Where two-direction pivoting is necessary, contact our distributor for specific recommendations.

Selection of piston rod diameter can be determined by consulting separate Engineering Brochure.

See Engineering Brochure for information concerning the application of long stroke cylinders.

See separate Accessories Brochure for additional data on cylinder mounting.

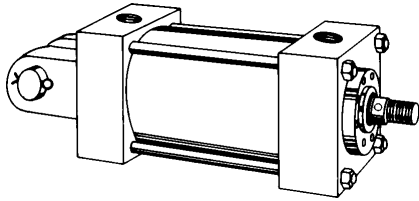
### IMPORTANT - Construction Variances

For information on construction variance on **Trunnion Front (TF), Trunnion Rear (TR) and Intermediate Trunnion (T) Mounts** refer to page MH-7.

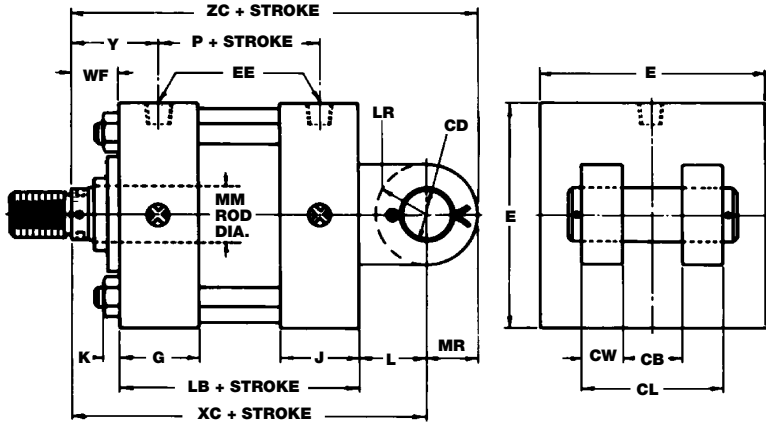
### Trunnion Dimensions

BORE	ROD DIA.	WF	XI MIN.	XI MAX.*	XG	XJ*	Y	ZB*
1 1/8	5/8	1 1/8	2 3/4	2 7/8*	1 23/32	3 29/32*	1 23/32	4 5/8*
1 1/2	5/8	1	3 1/4	2 7/8*	1 3/4	4 1/8*	1 15/16	4 27/32*
	1	1 3/8	3 5/8	3 1/4*	2 1/8	4 1/2*	2 5/16	5 7/32*
2	5/8	1	3 1/4	2 7/8*	1 3/4	4 1/8*	1 15/16	4 7/8*
	1	1 3/8	3 5/8	3 1/4*	2 1/8	4 1/2*	2 5/16	5 1/4*
2 1/2	1 3/8	1 5/8	3 7/8	3 1/2*	2 3/8	4 3/4*	2 9/16	5 1/2*
	5/8	1	3 1/4	3*	1 3/4	4 1/4*	1 15/16	5*
	1	1 3/8	3 5/8	3 3/8*	2 1/8	4 5/8*	2 5/16	5 3/8*
3 1/4	1 3/8	1 5/8	3 7/8	3 5/8*	2 3/8	4 7/8*	2 9/16	5 5/8*
	1 3/4	1 7/8	4 1/8	3 7/8*	2 5/8	5 1/8*	2 13/16	5 7/8*
	1	1 3/8	4	3 1/2*	2 1/4	5*	2 7/16	5 15/16*
4	1 3/8	1 5/8	4 1/4	3 7/8*	2 1/2	5 1/4*	2 11/16	6 3/16*
	1 3/4	1 7/8	4 1/2	4*	2 3/4	5 1/2*	2 15/16	6 7/16*
	2	2	4 5/8	4 1/8*	2 7/8	5 5/8*	3 1/16	6 9/16*
5	2 1/2	2 1/4	5	4 1/4*	3 1/8	5 7/8*	3 5/16	6 13/16*
	1	1 3/8	4 1/8	3 5/8*	2 1/4	5 1/4*	2 7/16	6 5/16*
	1 3/8	1 5/8	4 3/8	3 7/8*	2 1/2	5 1/2*	2 11/16	6 9/16*
6	1 3/4	1 7/8	4 5/8	4 1/8*	2 3/4	5 3/4*	2 15/16	6 13/16*
	2	2	4 3/4	4 1/4*	2 7/8	5 7/8*	3 1/16	6 15/16*
	2 1/2	2 1/4	5	4 1/2*	3 1/8	6 1/8*	3 5/16	7 3/16*
7	3 1/2	2 1/4	5	4 1/2*	3 1/8	6 1/8*	3 5/16	7 3/16*
	1 3/8	1 5/8	4 7/8	3 7/8*	2 5/8	5 7/8*	2 13/16	7 1/16*
	1 3/4	1 7/8	5 1/8	4 1/8*	2 7/8	6 1/8*	3 1/16	7 5/16*
8	2	2	5 1/4	4 1/4*	3	6 1/4*	3 9/16	7 7/16*
	2 1/2	2 1/4	5 1/2	4 1/2*	3 1/4	6 1/2*	3 7/16	7 11/16*
	3	2 1/4	5 1/2	4 1/2*	3 1/4	6 1/2*	3 7/16	7 11/16*
9	3 1/2	2 1/4	5 1/2	4 1/2*	3 1/4	6 1/2*	3 7/16	7 11/16*
	4	2 1/4	5 1/2	4 5/8*	3 1/4	6 5/8*	3 7/16	7 15/16*
	4 1/2	2 1/4	5 1/2	4 5/8*	3 1/4	6 5/8*	3 7/16	7 15/16*
10	5	2 1/4	5 1/2	4 5/8*	3 1/4	6 5/8*	3 7/16	7 15/16*
	1 3/8	1 5/8	4 7/8	4*	2 5/8	6*	2 13/16	7 5/16*
	1 3/4	1 7/8	5 1/8	4 1/4*	2 7/8	6 1/4*	3 1/16	7 9/16*
11	2	2	5 1/4	4 3/8*	3	6 3/8*	3 9/16	7 11/16*
	2 1/2	2 1/4	5 1/2	4 5/8*	3 1/4	6 5/8*	3 7/16	7 15/16*
	3	2 1/4	5 1/2	4 5/8*	3 1/4	6 5/8*	3 7/16	7 15/16*
12	3 1/2	2 1/4	5 1/2	4 5/8*	3 1/4	6 5/8*	3 7/16	7 15/16*
	4	2 1/4	5 1/2	4 5/8*	3 1/4	6 5/8*	3 7/16	7 15/16*
	4 1/2	2 1/4	5 1/2	4 5/8*	3 1/4	6 5/8*	3 7/16	7 15/16*
13	5	2 1/4	5 1/2	4 5/8*	3 1/4	6 5/8*	3 7/16	7 15/16*
	1 3/8	1 5/8	4 7/8	4*	2 5/8	6*	2 13/16	7 5/16*
	1 3/4	1 7/8	5 1/8	4 1/4*	2 7/8	6 1/4*	3 1/16	7 9/16*
14	2	2	5 1/4	4 3/8*	3	6 3/8*	3 9/16	7 11/16*
	2 1/2	2 1/4	5 1/2	4 5/8*	3 1/4	6 5/8*	3 7/16	7 15/16*
	3	2 1/4	5 1/2	4 5/8*	3 1/4	6 5/8*	3 7/16	7 15/16*
15	3 1/2	2 1/4	5 1/2	4 5/8*	3 1/4	6 5/8*	3 7/16	7 15/16*
	4	2 1/4	5 1/2	4 5/8*	3 1/4	6 5/8*	3 7/16	7 15/16*
	4 1/2	2 1/4	5 1/2	4 5/8*	3 1/4	6 5/8*	3 7/16	7 15/16*
16	5	2 1/4	5 1/2	4 5/8*	3 1/4	6 5/8*	3 7/16	7 15/16*
	1 3/8	1 5/8	4 7/8	4*	2 5/8	6*	2 13/16	7 5/16*
	1 3/4	1 7/8	5 1/8	4 1/4*	2 7/8	6 1/4*	3 1/16	7 9/16*
17	2	2	5 1/4	4 3/8*	3	6 3/8*	3 9/16	7 11/16*
	2 1/2	2 1/4	5 1/2	4 5/8*	3 1/4	6 5/8*	3 7/16	7 15/16*
	3	2 1/4	5 1/2	4 5/8*	3 1/4	6 5/8*	3 7/16	7 15/16*
18	3 1/2	2 1/4	5 1/2	4 5/8*	3 1/4	6 5/8*	3 7/16	7 15/16*
	4	2 1/4	5 1/2	4 5/8*	3 1/4	6 5/8*	3 7/16	7 15/16*
	4 1/2	2 1/4	5 1/2	4 5/8*	3 1/4	6 5/8*	3 7/16	7 15/16*
19	5	2 1/4	5 1/2	4 5/8*	3 1/4	6 5/8*	3 7/16	7 15/16*
	1 3/8	1 5/8	4 7/8	4*	2 5/8	6*	2 13/16	7 5/16*
	1 3/4	1 7/8	5 1/8	4 1/4*	2 7/8	6 1/4*	3 1/16	7 9/16*
20	2	2	5 1/4	4 3/8*	3	6 3/8*	3 9/16	7 11/16*
	2 1/2	2 1/4	5 1/2	4 5/8*	3 1/4	6 5/8*	3 7/16	7 15/16*
	3	2 1/4	5 1/2	4 5/8*	3 1/4	6 5/8*	3 7/16	7 15/16*
21	3 1/2	2 1/4	5 1/2	4 5/8*	3 1/4	6 5/8*	3 7/16	7 15/16*
	4	2 1/4	5 1/2	4 5/8*	3 1/4	6 5/8*	3 7/16	7 15/16*
	4 1/2	2 1/4	5 1/2	4 5/8*	3 1/4	6 5/8*	3 7/16	7 15/16*
22	5	2 1/4	5 1/2	4 5/8*	3 1/4	6 5/8*	3 7/16	7 15/16*
	1 3/8	1 5/8	4 7/8	4*	2 5/8	6*	2 13/16	7 5/16*
	1 3/4	1 7/8	5 1/8	4 1/4*	2 7/8	6 1/4*	3 1/16	7 9/16*
23	2	2	5 1/4	4 3/8*	3	6 3/8*	3 9/16	7 11/16*
	2 1/2	2 1/4	5 1/2	4 5/8*	3 1/4	6 5/8*	3 7/16	7 15/16*
	3	2 1/4	5 1/2	4 5/8*	3 1/4	6 5/8*	3 7/16	7 15/16*
24	3 1/2	2 1/4	5 1/2	4 5/8*	3 1/4	6 5/8*	3 7/16	7 15/16*
	4	2 1/4	5 1/2	4 5/8*	3 1/4	6 5/8*	3 7/16	7 15/16*
	4 1/2	2 1/4	5 1/2	4 5/8*	3 1/4	6 5/8*	3 7/16	7 15/16*
25	5	2 1/4	5 1/2	4 5/8*	3 1/4	6 5/8*	3 7/16	7 15/16*
	1 3/8	1 5/8	4 7/8	4*	2 5/8	6*	2 13/16	7 5/16*
	1 3/4	1 7/8	5 1/8	4 1/4*	2 7/8	6 1/4*	3 1/16	7 9/16*
26	2	2	5 1/4	4 3/8*	3	6 3/8*	3 9/16	7 11/16*
	2 1/2	2 1/4	5 1/2	4 5/8*	3 1/4	6 5/8*	3 7/16	7 15/16*
	3	2 1/4	5 1/2	4 5/8*	3 1/4	6 5/8*	3 7/16	7 15/16*
27	3 1/2	2 1/4	5 1/2	4 5/8*	3 1/4	6 5/8*	3 7/16	7 15/16*
	4	2 1/4	5 1/2	4 5/8*	3 1/4	6 5/8*	3 7/16	7 15/16*
	4 1/2	2 1/4	5 1/2	4 5/8*	3 1/4	6 5/8*	3 7/16	7 15/16*
28	5	2 1/4	5 1/2	4 5/8*	3 1/4	6 5/8*	3 7/16	7 15/16*
	1 3/8	1 5/8	4 7/8	4*	2 5/8	6*	2 13/16	7 5/16*
	1 3/4	1 7/8	5 1/8	4 1/4*	2 7/8	6 1/4*	3 1/16	7 9/16*
29	2	2	5 1/4	4 3/8*	3	6 3/8*	3 9/16	7 11/16*
	2 1/2	2 1/4	5 1/2	4 5/8*	3 1/4	6 5/8*	3 7/16	7 15/16*
	3	2 1/4	5 1/2	4 5/8*	3 1/4	6 5/8*	3 7/16	7 15/16*
30	3 1/2	2 1/4	5 1/2	4 5/8*	3 1/4	6 5/8*	3 7/16	7 15/16*
	4	2 1/4	5 1/2	4 5/8*	3 1/4	6 5/8*	3 7/16	7 15/16*
	4 1/2	2 1/4	5 1/2	4 5/8*	3 1/4	6 5/8*	3 7/16	7 15/16*
31	5	2 1/4	5 1/2	4 5/8*	3 1/4	6 5/8*	3 7/16	7 15/16*
	1 3/8	1 5/8	4 7/8	4*	2 5/8	6*	2 13/16	7 5/16*
	1 3/4	1 7/8	5 1/8	4 1/4*	2 7/8	6 1/4*	3 1/16	7 9/16*
32	2	2	5 1/4	4 3/8*	3	6 3/8*	3 9/16	7 11/16*
	2 1/2	2 1/4	5 1/2	4 5/8*	3 1/4	6 5/8*	3 7/16	7 15/16*
	3	2 1/4	5 1/2	4 5/8*	3 1/4	6 5/8*	3 7/16	7 15/16*
33	3 1/2	2 1/4	5 1/2	4 5/8*	3 1/4	6 5/8*	3 7/16	7 15/16*
	4	2 1/4	5 1/2	4 5/8*	3 1/4	6 5/8*	3 7/16	7 15/16*
	4 1/2	2 1/4	5 1/2	4 5/8*	3 1/4	6 5/8*	3 7/16	7 15/16*
34	5	2 1/4	5 1/2	4 5/8*	3 1/4	6 5/8*	3 7/16	7 15/16*
	1 3/8	1 5/8	4 7/8	4*	2 5/8	6*	2 13/16	7 5/16*
	1 3/4	1 7/8	5 1/8	4 1/4*	2 7/8	6 1/4*	3 1/16	7 9/16*
35	2	2	5 1/4	4 3/8*	3	6 3/8*	3 9/16	7 11/16*
	2 1/2	2 1/4	5 1/2	4 5/8*	3 1/4	6 5/8*	3 7/16	7 15/16*
	3	2 1/4	5 1/2	4 5/8*	3 1/4	6 5/8*	3 7/16	7 15/16*
36	3 1/2	2 1/4	5 1/2	4 5/8*	3 1/4	6 5/8*	3 7/16	7 15/16*
	4	2 1/4	5 1/2	4 5/8*	3 1/4	6 5/8*	3 7/16	7 15/16*
	4 1/2	2 1/4	5 1/2	4 5/8*	3 1/4	6 5/8*	3 7/16	7 15/16*
37	5	2 1/4	5 1/2	4 5/8*	3 1/4	6 5/8*	3 7/16	7 15/16*
	1 3/8	1 5/8	4 7/8	4*	2 5/8	6*	2 13/16	7 5/16*
	1 3/4	1 7/8	5 1/8	4 1/4*	2 7/8	6 1/4*	3 1/16	7 9/16*
38	2	2	5 1/4	4 3/8*	3	6 3/8*	3 9/16	7 11/16*
	2 1/2	2 1/4	5 1/2	4 5/8*	3 1/4	6 5/8*	3 7/16	7 15/16*
	3	2 1/4	5 1/2	4 5/8*	3 1/4	6 5/8*	3 7/16	7 15/16*
39	3 1/2	2 1/4	5 1/2	4 5/8*	3 1/4	6 5/8*	3 7/16	7 15/16*
	4	2 1/4	5 1/2	4 5/8*	3 1/4	6 5		

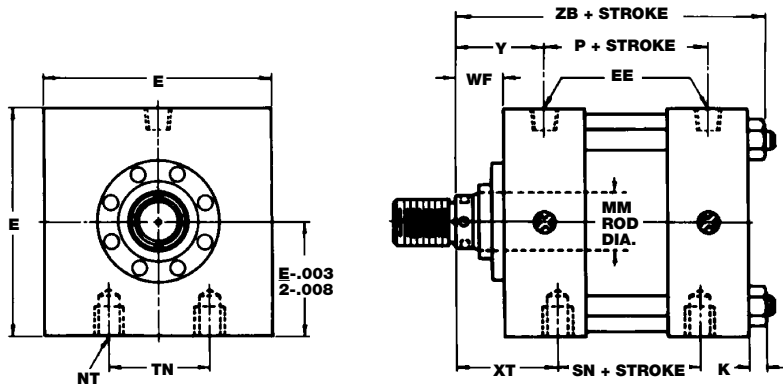
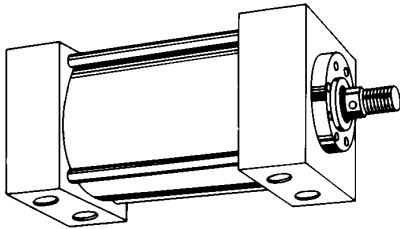
## CLEVIS MOUNT STYLE C (MP1)\*



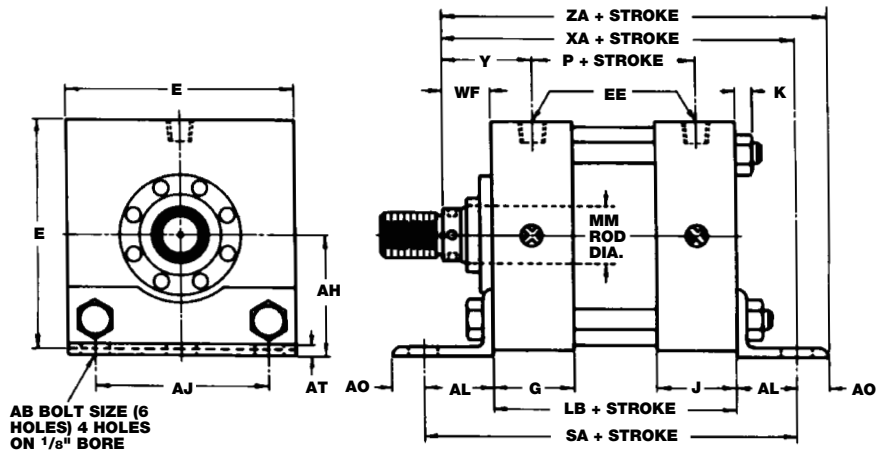
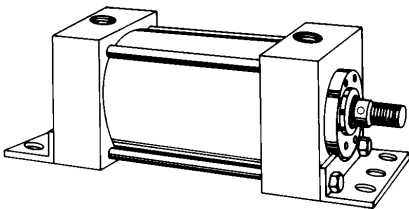
PIVOT MOUNT IS AVAILABLE  
PIVOT WIDTH IS SAME AS CB



## SIDE FLUSH MOUNT STYLE SF (MS4)\*



## FOOT BRACKET MOUNT STYLE FB (MS1)\*



\*ANSI/B93.1-1964 Mounting Style Designation.

## Side Flush Note: Thread Depth and Side Flush Mounting Availability Chart

BORE	ROD DIA.	THREAD DEPTH
1 1/8	5/8	3/8
1 1/2	5/8	3/8
2	5/8, 1, 1 3/8	7/16
2 1/2	5/8, 1, 1 3/8	5/8
3 1/4	1, 1 3/8, 1 3/4	3/4
4	1, 1 3/8, 1 3/4, 2	3/4
5	1, 1 3/8, 1 3/4, 2, 2 1/2	1 1/4
6	1 3/8, 1 3/4, 2, 2 1/2, 3, 3 1/2	1 1/8
7	1 3/8, 1 3/4, 2, 2 1/2, 3, 3 1/2, 4, 4 1/2	1 1/8
8	ALL	1 1/8

NOTE: Side flush mounting is available with usable thread depths shown above.

### IMPORTANT – Construction Variances

For information on construction variance on **Clevis (C)** and **Side Flush (SF) Mounts**, refer to page MH-7.

### Foot Bracket Mount Variance –

There is a construction variance in the 1 1/8", 1 1/2", and 2" bore sizes, and the 2 1/2" bore with 1 3/8" and 1 3/4" rod diameters, the 3 1/4" bore with the 1 3/4" and 2" rod diameters, the 4" bore with 2 1/2" rod diameter, the 5" bore with 3" and 3 1/2" diameter rods and the 6" bore with the 4" diameter rod. The round gland retainer shown on the preceding page is not employed on these sizes. A square retainer the same square size as the head is used instead.

## Clevis, Side Flush and Foot Bracket Dimensions

BORE	ROD DIA.	SA*	WF	XA*	XC*	XT	Y	ZA*	ZB*	ZC*
1 1/8	5/8	5 3/4*	1 1/8	5 3/8*	5 5/16*	1 25/32	1 23/32	—	4 5/8*	5 3/4*
1 1/2	5/8	6*	1	5 5/8*	5 3/8*	1 15/16	1 15/16	6*	4 27/32*	5 7/8*
	1	6*	1 3/8	6*	5 3/4*	2 5/16	2 5/16	6 3/8*	5 7/32*	6 1/4*
2	5/8	6*	1	5 5/8*	5 3/8*	1 15/16	1 15/16	6*	4 7/8*	5 7/8*
	1	6*	1 3/8	6*	5 3/4*	2 5/16	2 5/16	6 3/8*	5 1/4*	6 1/4*
2 1/2	1 3/8	6*	1 5/8	6 1/4*	6*	2 9/16	2 9/16	6 3/8*	5 1/2*	6 1/2*
	5/8	5 1/4*	1	5 3/4*	5 1/2*	1 15/16	1 15/16	6 1/8*	5*	6*
	1	5 1/4*	1 3/8	6 1/8*	5 7/8*	2 5/16	2 5/16	6 1/2*	5 3/8*	6 3/8*
3 1/4	1 3/8	6 1/8*	1 5/8	6 3/8*	6 1/8*	2 9/16	2 9/16	6 3/4*	5 5/8*	6 5/8*
	1 3/4	6 1/8*	1 7/8	6 5/8*	6 3/8*	2 9/16	2 13/16	7*	5 7/8*	6 3/8*
	1	6 3/4*	1 3/8	6 7/8*	6 7/8*	2 7/16	2 7/16	7 3/8*	5 15/16*	7 5/8*
	1 3/8	7 3/8*	1 5/8	7 1/8*	7 1/8*	2 11/16	2 11/16	7 5/8*	6 3/16*	7 7/8*
4	1 3/4	7 3/8*	1 7/8	7 3/8*	7 3/8*	2 15/16	2 15/16	7 1/8*	6 7/16*	8 1/8*
	2	7 3/8*	2	7 1/2*	7 1/2*	3 1/16	3 1/16	8*	6 3/16*	8 1/4*
	1	6 3/4*	1 3/8	6 7/8*	6 7/8*	2 7/16	2 7/16	7 3/8*	5 15/16*	7 5/8*
	1 3/8	6 3/4*	1 5/8	7 1/8*	7 1/8*	2 11/16	2 11/16	7 5/8*	6 3/16*	7 7/8*
	1 3/4	7 3/8*	1 7/8	7 3/8*	7 3/8*	2 15/16	2 15/16	7 1/8*	6 7/16*	8 1/8*
5	2	7 3/8*	2	7 1/2*	7 1/2*	3 1/16	3 1/16	8*	6 9/16*	8 1/4*
	2 1/2	7 3/8*	2 1/4	7 3/4*	7 3/4*	3 5/16	3 5/16	8 1/4*	6 13/16*	8 1/2*
	1	7 1/4*	1 3/8	7 1/4*	7 1/8*	2 7/16	2 7/16	7 1/8*	6 5/16*	7 7/8*
	1 3/8	7 1/4*	1 5/8	7 1/2*	7 3/8*	2 11/16	2 11/16	8 1/8*	6 3/16*	8 1/8*
	1 3/4	7 1/4*	1 7/8	7 3/4*	7 5/8*	2 15/16	2 15/16	8 3/8*	6 13/16*	8 3/8*
	2	7 1/4*	2	7 1/2*	7 3/4*	3 1/16	3 1/16	8 3/4*	6 15/16*	8 1/2*
6	2 1/2	7 1/4*	2 1/4	8 1/8*	8*	3 5/16	3 5/16	8 3/4*	7 3/16*	8 3/4*
	3	7 1/8*	2 1/4	8 1/8*	8*	3 5/16	3 5/16	8 3/4*	7 3/16*	8 3/4*
	3 1/2	7 1/8*	2 1/4	8 1/8*	8*	3 5/16	3 5/16	8 3/4*	7 3/16*	8 3/4*
	1 3/8	7 3/4*	1 5/8	8*	8 1/8*	2 13/16	2 13/16	8 5/8*	7 1/16*	9 1/8*
	1 3/4	7 3/4*	1 7/8	8 1/4*	8 3/8*	3 1/16	3 1/16	8 7/8*	7 5/16*	9 3/8*
	2	7 3/4*	2	8 3/8*	8 1/2*	3 3/16	3 3/16	9*	7 7/16*	9 1/2*
	2 1/2	7 3/4*	2 1/4	8 5/8*	8 3/4*	3 7/16	3 7/16	9 1/4*	7 11/16*	9 3/4*
	3	7 3/4*	2 1/4	8 5/8*	8 3/4*	3 7/16	3 7/16	9 1/4*	7 11/16*	9 3/4*
7	3 1/2	8 1/2*	2 1/4	8 5/8*	8 3/4*	3 7/16	3 7/16	9 1/4*	7 11/16*	9 3/4*
	4	8 1/2*	2 1/4	8 5/8*	8 3/4*	3 7/16	3 7/16	9 1/4*	7 11/16*	9 3/4*
	1 3/8	8 3/4*	1 5/8	8 9/16*	8 1/4*	2 13/16	2 13/16	9 1/4*	7 5/16*	9 1/4*
	1 3/4	8 3/4*	1 7/8	8 13/16*	8 1/2*	3 1/16	3 1/16	9 1/2*	7 9/16*	9 1/2*
	2	8 3/4*	2	8 15/16*	8 5/8*	3 3/16	3 3/16	9 5/8*	7 11/16*	9 5/8*
	2 1/2	8 3/4*	2 1/4	9 3/16*	8 7/8*	3 7/16	3 7/16	9 7/8*	7 15/16*	9 7/8*
	3	8 3/4*	2 1/4	9 3/16*	8 7/8*	3 7/16	3 7/16	9 7/8*	7 15/16*	9 7/8*
	3 1/2	8 3/4*	2 1/4	9 3/16*	8 7/8*	3 7/16	3 7/16	9 7/8*	7 15/16*	9 7/8*
	4	8 3/4*	2 1/4	9 3/16*	8 7/8*	3 7/16	3 7/16	9 7/8*	7 15/16*	9 7/8*
	4 1/2	8 3/4*	2 1/4	9 3/16*	8 7/8*	3 7/16	3 7/16	9 7/8*	7 15/16*	9 7/8*
8	5	8 3/4*	2 1/4	9 3/16*	8 7/8*	3 7/16	3 7/16	9 7/8*	7 15/16*	9 7/8*
	1 3/8	8 3/4*	1 5/8	8 9/16*	8 1/4*	2 13/16	2 13/16	9 1/4*	7 5/16*	9 1/4*
	1 3/4	8 3/4*	1 7/8	8 13/16*	8 1/2*	3 1/16	3 1/16	9 1/2*	7 9/16*	9 1/2*
	2	8 3/4*	2	8 15/16*	8 5/8*	3 3/16	3 3/16	9 5/8*	7 11/16*	9 5/8*
	2 1/2	8 3/4*	2 1/4	9 3/16*	8 7/8*	3 7/16	3 7/16	9 7/8*	7 15/16*	9 7/8*
	3	8 3/4*	2 1/4	9 3/16*	8 7/8*	3 7/16	3 7/16	9 7/8*	7 15/16*	9 7/8*
	3 1/2	8 3/4*	2 1/4	9 3/16*	8 7/8*	3 7/16	3 7/16	9 7/8*	7 15/16*	9 7/8*
	4	8 3/4*	2 1/4	9 3/16*	8 7/8*	3 7/16	3 7/16	9 7/8*	7 15/16*	9 7/8*
	4 1/2	8 3/4*	2 1/4	9 3/16*	8 7/8*	3 7/16	3 7/16	9 7/8*	7 15/16*	9 7/8*
	5	8 3/4*	2 1/4	9 3/16*	8 7/8*	3 7/16	3 7/16	9 7/8*	7 15/16*	9 7/8*
5 1/2	8 3/4*	2 1/4	9 3/16*	8 7/8*	3 7/16	3 7/16	9 7/8*	7 15/16*	9 7/8*	

\*Be sure to add stroke to this dimension.

## Clevis, Side Flush and Foot Bracket Dimensions

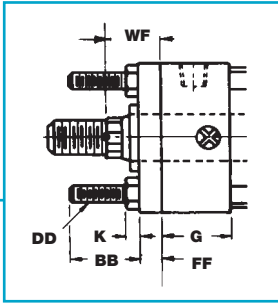
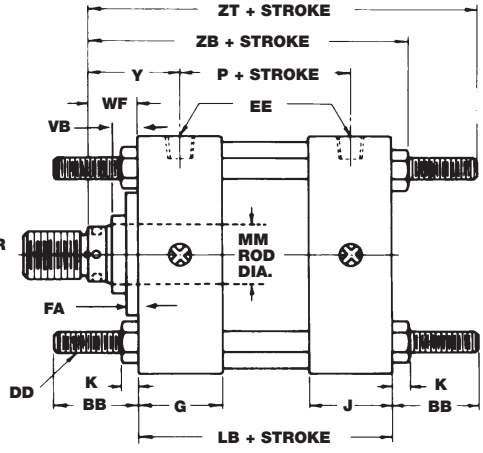
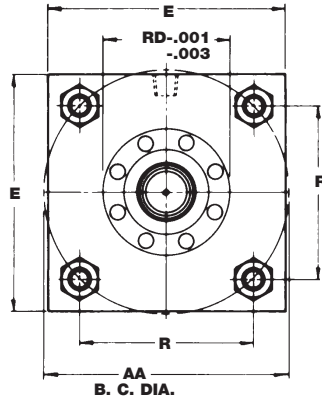
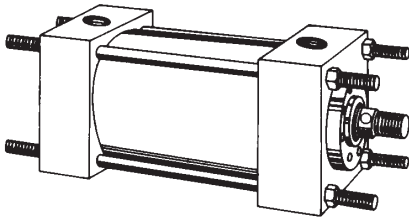
BORE	AB**	AH	AJ	AL	AO	AT	CB	CD	CL	CW	E	EE NPT†	EE SAE	G	J	K	L	LB*	LR	MR	NT	P*	SN*	TN
1 1/8	5/16	1 1/16	1 1/8	1	3/8	1/8	5/8	3/8	1 1/4	5/16	1 3/4	1/4	-6	1 1/8	1	1/4	15/16	3 1/4*	3/4	3/8	5/16-18	2 3/16*	2 1/16*	—
1 1/2	3/8	1 3/16	1 1/4	1	3/8	1/8	3/4	1/2	1 3/4	1/2	2	3/8	-6	1 1/2	1	7/32	3/4	3 5/8*	1/2	1/2	1 1/4-20	2 1/4*	2 1/4*	5/8
2	3/8	1 7/16	1 3/4	1	3/8	1/8	3/4	1/2	1 3/4	1/2	2 1/2	3/8	-6	1 1/2	1	1/4	3/4	3 5/8*	1/2	1/2	5/16-18	2 1/4*	2 1/4*	7/8
2 1/2	3/8	1 5/8	2 1/4	1	3/8	1/8	3/4	1/2	1 3/4	1/2	3	3/8	-6	1 1/2	1	1/4	3/4	3 3/4*	1/2	1/2	3/8-16	2 3/8*	2 3/8*	1 1/4
3 1/4	1/2	1 15/16	2 3/4	1 1/4	1/2	1/8	1 1/4	3/4	2 1/2	5/8	3 3/4	1/2	-10	1 3/4	1 1/4	5/16	1 1/4	4 1/4*	3/4	3/4	1 1/2-13	2 5/8*	2 5/8*	1 1/2
4	1/2	2 1/4	3 1/2	1 1/4	1/2	1/8	1 1/4	3/4	2 1/2	5/8	4 1/2	1/2	-10	1 3/4	1 1/4	5/16	1 1/4	4 1/4*	3/4	3/4	1 1/2-13	2 5/8*	2 5/8*	2 1/16
5	5/8	2 3/4	4 1/4	1 3/8	5/8	3/16	1 1/4	3/4	2 1/2	5/8	5 1/2	1/2	-10	1 3/4	1 1/4	7/16	1 1/4	4 1/2*	3/4	3/4	5/8-11	2 7/8*	2 7/8*	2 1/16
6	3/4	3 1/4	5 1/4	1 3/8	5/8	3/16	1 1/2	1	3	3/4	6 1/2	3/4	-12	2	1 1/2	7/16	1 1/2	5*	1	1	3/4-10	3 1/8*	3 1/8*	3 1/4
7	3/4	—	6 1/8	1 13/16	1 1/16	1/4	1 1/2	1	3	3/4	7 1/2	3/4	-12	2	1 1/2	9/16	1 1/2	5 1/8*	1	1	3/4-10	3 1/4*	3 1/4*	3 1/2
8	3/4	—	7 1/8	1 13/16	1 1/16	1/4	1 1/2	1	3	3/4	8 1/2	3/4	-12	2	1 1/2	9/16	1 1/2	5 1/8*	1	1	3/4-10	3 1/4*	3 1/4*	4 1/2

\*Be sure to add stroke to this dimension.

\*\*Clearance holes for indicated bolt size.

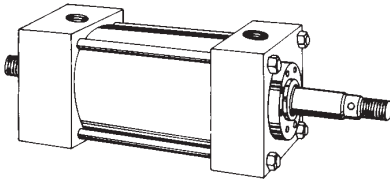
†Alternate port at no extra charge. SAE port is standard.

### TIE RODS EXTENDED

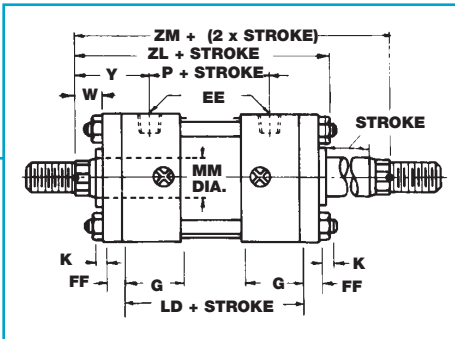
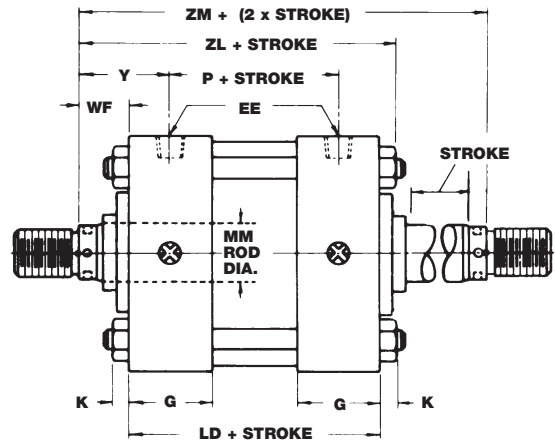
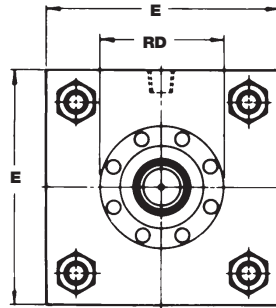


NX - Neither (MX0)\*  
 BX - Both (MX1)\*  
 RX - Rear (MX2)\*  
 FX - Front (MX3)\*  
 \*ANSI/B93.1-1964  
 Mounting Style  
 Designation.

### BASIC DOUBLE ROD CYLINDERS



Available in all except C mounts.



## Double Rod End Cylinders

Double Rod End cylinders are specified for many reasons, some of which are as follows:

1. A simultaneous push and pull requirement.
2. Both rod ends are fixed and the cylinder moves – such as on a machine slide.
3. One rod does the work and the other serves to indicate position or to trip switches.
4. A double rod end cylinder has rod bearings at each end and therefore offers more resistance to deflection and side loading.

When the rod ends of a double rod end cylinder are not to be the same, such as a style 2 on one end and a style 4 on the other, be sure to so specify and to identify which end is which in relation to the mount. For example, on a Front Head Flange mount double rod end cylinder, specify style 2 rod end on flange end of cylinder and style 4 on opposite end.

Refer to Pages MH-21 and MH-22 for Rod End Information.

### IMPORTANT - Construction Variances

For information on construction variance on **Tie Rods Extended Mounts** and **Double Rod End Cylinders** refer to page MH-8.

## Tie Rod and Double Rod Dimensions

BORE	ROD DIA.	FA	RD	VB	W	WF	Y	ZB*	ZL*	ZM*	ZT*
1 1/8	5/8	—	—	—	5/8	1 1/8	1 23/32	4 5/8	5 1/4	5 5/8	5 3/8
1 1/2	5/8	—	—	—	5/8	1	1 15/16	4 21/32	5 23/32	6 1/8	5 9/8
	1	—	—	—	1	1 3/8	2 5/16	5 7/32	6 3/32	6 1/8	6*
2	5/8	—	—	—	5/8	1	1 15/16	4 7/8	5 3/4	6 1/8	5 3/4
	1	—	—	—	1	1 3/8	2 5/16	5 1/4	6 1/8	6 1/8	6 1/8
	1 3/8	—	—	—	1 1/4	1 5/8	2 9/16	5 1/2	6 3/8	7 3/8	6 3/8
2 1/2	5/8	11/32	2.187	5/8	—	1	1 15/16	5*	5 1/8	6 1/4	5 1/8
	1	11/32	2.375	7/8	—	1 3/8	2 5/16	5 3/8	6 1/4	7*	6 1/4
	1 3/8	—	—	—	1 1/4	1 5/8	2 9/16	5 5/8	6 1/2	7 1/2	6 1/2
	1 3/4	—	—	—	1 3/8	1 7/8	2 13/16	5 7/8	6 3/4	8*	6 3/4
3 1/4	1	11/32	2.375	7/8	—	1 3/8	2 1/16	5 15/16	7 1/16	7 1/2	7*
	1 3/8	19/32	2.875	1	—	1 5/8	2 11/16	6 3/16	7 5/16	8*	7 1/4
	1 3/4	19/32	3.250	1 1/8	—	1 7/8	2 15/16	6 7/16	7 9/16	8 1/2	7 1/2
	2	—	—	—	1 3/8	2	3 1/16	6 9/16	7 11/16	8 3/4	7 3/8
4	1	11/32	2.375	7/8	—	1 3/8	2 1/16	5 15/16	7 1/16	7 1/2	7*
	1 3/8	19/32	2.875	1	—	1 5/8	2 11/16	6 3/16	7 5/16	8*	7 1/4
	1 3/4	19/32	3.250	1 1/8	—	1 7/8	2 15/16	6 7/16	7 9/16	8 1/2	7 1/2
	2	19/32	3.562	1 1/8	—	2	3 1/16	6 9/16	7 11/16	8 3/4	7 3/8
	2 1/2	19/32	4.000	1 1/4	—	2 1/4	3 9/16	6 13/16	7 15/16	9 1/4	7 1/8
5	1	11/32	2.375	7/8	—	1 3/8	2 1/16	5 5/16	7 1/16	7 3/4	7 1/16
	1 3/8	19/32	2.875	1	—	1 5/8	2 11/16	6 9/16	7 11/16	8 1/4	7 15/16
	1 3/4	19/32	3.250	1 1/8	—	1 7/8	2 15/16	6 13/16	7 15/16	8 3/4	8 3/16
	2	19/32	3.562	1 1/8	—	2	3 1/16	6 15/16	7 15/16	9*	8 5/16
	2 1/2	19/32	4.000	1 1/4	—	2 1/4	3 9/16	6 19/16	7 3/16	8 5/16	8 1/16
	3	19/32	4.750	1 1/4	—	2 1/4	3 5/16	7 3/16	8 5/16	9 1/2	8 1/16
	3 1/2	23/32	5.187	1 1/4	—	2 1/4	3 9/16	7 3/16	8 5/16	9 1/2	8 1/16
6	1 3/8	19/32	2.875	1	—	1 5/8	2 13/16	7 1/16	8 5/16	8 3/4	8 1/16
	1 3/4	19/32	3.250	1 1/8	—	1 7/8	2 13/16	7 1/16	8 5/16	9 1/4	8 11/16
	2	19/32	3.562	1 1/8	—	2	3 1/16	7 1/16	8 11/16	9 1/4	8 13/16
	2 1/2	19/32	4.000	1 1/4	—	2 1/4	3 1/16	7 1/16	8 15/16	10*	8 15/16
	3	19/32	4.750	1 1/4	—	2 1/4	3 1/16	7 1/16	8 15/16	10*	8 15/16
	3 1/2	23/32	5.187	1 1/4	—	2 1/4	3 1/16	7 1/16	8 15/16	10*	8 15/16
	4	23/32	5.750	1 1/4	—	2 1/4	3 1/16	7 1/16	8 15/16	10*	8 15/16
7	1 3/8	19/32	2.875	1	—	1 5/8	2 13/16	7 5/16	8 13/16	8 7/8	9 1/16
	1 3/4	19/32	3.250	1 1/8	—	1 7/8	3 1/16	7 9/16	8 1/16	9 3/8	9 5/16
	2	19/32	3.562	1 1/8	—	2	3 3/16	7 11/16	8 3/16	9 5/8	9 1/16
	2 1/2	19/32	4.000	1 1/4	—	2 1/4	3 1/16	7 15/16	8 7/16	10 1/8	9 11/16
	3	19/32	4.750	1 1/4	—	2 1/4	3 1/16	7 15/16	8 7/16	10 1/8	9 11/16
	3 1/2	23/32	5.187	1 1/4	—	2 1/4	3 1/16	7 15/16	8 7/16	10 1/8	9 11/16
	4	23/32	5.750	1 1/4	—	2 1/4	3 1/16	7 15/16	8 7/16	10 1/8	9 11/16
	4 1/2	3/4	6.250	1 1/4	—	2 1/4	3 1/16	7 15/16	8 7/16	10 1/8	9 11/16
	5	3/4	6.750	1 1/4	—	2 1/4	3 1/16	7 15/16	8 7/16	10 1/8	9 11/16
8	1 3/8	19/32	2.875	1	—	1 5/8	2 13/16	7 5/16	8 13/16	8 7/8	9 1/16
	1 3/4	19/32	3.250	1 1/8	—	1 7/8	3 1/16	7 9/16	8 1/16	9 3/8	9 5/16
	2	19/32	3.562	1 1/8	—	2	3 3/16	7 11/16	8 3/16	9 5/8	9 1/16
	2 1/2	19/32	4.000	1 1/4	—	2 1/4	3 1/16	7 15/16	8 7/16	10 1/8	9 11/16
	3	19/32	4.750	1 1/4	—	2 1/4	3 1/16	7 15/16	8 7/16	10 1/8	9 11/16
	3 1/2	23/32	5.187	1 1/4	—	2 1/4	3 1/16	7 15/16	8 7/16	10 1/8	9 11/16
	4	23/32	5.750	1 1/4	—	2 1/4	3 1/16	7 15/16	8 7/16	10 1/8	9 11/16
	4 1/2	3/4	6.250	1 1/4	—	2 1/4	3 1/16	7 15/16	8 7/16	10 1/8	9 11/16
	5	3/4	6.750	1 1/4	—	2 1/4	3 1/16	7 15/16	8 7/16	10 1/8	9 11/16
	5 1/2	3/4	7.250	1 1/4	—	2 1/4	3 1/16	7 15/16	8 7/16	10 1/8	9 11/16

\*Add stroke to these dimensions. Add 2X stroke to ZM dimensions.

## Tie Rod and Double Rod Dimensions

BORE	AA	BB	DD	E	EE NPT†	EE SAE	FF	G	J	K	LB*	LD*	P*	R
1 1/8	1.68	1	1/4-28	1 3/4	1/4	-6	1/2	1 1/8	1	1/4	3 1/4	3 3/8	2 3/16	1.19
1 1/2	2.02	1	1/4-28	2	3/8	-6	3/8	1 1/2	1	7/32	3 5/8	4 1/8	2 1/4	1.43
2	2.6	1 1/8	5/16-24	2 1/2	3/8	-6	3/8	1 1/2	1	1/4	3 5/8	4 1/8	2 1/4	1.84
2 1/2	3.1	1 1/8	5/16-24	3	3/8	-6	3/8	1 1/2	1	1/4	3 3/4	4 1/4	2 3/8	2.19
3 1/4	3.93	1 3/8	3/8-24	3 3/4	1/2	-10	5/8	1 3/4	1 1/4	5/16	4 1/4	4 3/4	2 5/8	2.76
4	4.7	1 3/8	3/8-24	4 1/2	1/2	-10	—	1 3/4	1 1/4	5/16	4 1/4	4 3/4	2 5/8	3.32
5	5.8	1 13/16	1/2-20	5 1/2	1/2	-10	—	1 3/4	1 1/4	7/16	4 1/2	5	2 7/8	4.10
6	6.9	1 13/16	1/2-20	6 1/2	3/4	-12	—	2	1 1/2	7/16	5	5 1/2	3 1/8	4.88
7	8.1	2 5/16	5/8-18	7 1/2	3/4	-12	—	2	1 1/2	9/16	5 1/8	5 5/8	3 1/4	5.73
8	9.1	2 5/16	5/8-18	8 1/2	3/4	-12	—	2	1 1/2	9/16	5 1/8	5 5/8	3 1/4	6.44

†Alternate port at no extra charge. SAE port is standard.

\*Add stroke to these dimensions.

# Rod End Dimensions

1/8" THRU 8" BORES

## Rod End Dimensions

BORE	ROD DIA.	A	AC	AD	AE	AF DIA.	B DIA. -.001 -.003	C	CC	D	KK	NA DIA. ±.002	V	VA*	WRENCH FLATS OR SPANNER HOLES	
															MALE ROD END	STYLE 4 ROD END
1 1/8	5/8	3/4	1 1/8	5/8	1/4	3/8	1 1/8	3/8	1/2-20	1/2	7/16-20	.594	1/4	—	W.F.	W.F.
1 1/2	5/8	3/4	1 1/8	5/8	1/4	3/8	1 1/8	3/8	1/2-20	1/2	7/16-20	.594	1/4	—	W.F.	W.F.
	1	1 1/8	1 1/2	15/16	3/8	11/16	1 1/2	1/2	7/8-14	13/16	3/4-16	.968	1/2	—	W.F.	W.F.
2	5/8	3/4	1 1/8	5/8	1/4	3/8	1 1/8	3/8	1/2-20	1/2	7/16-20	.594	1/4	—	W.F.	W.F.
	1	1 1/8	1 1/2	15/16	3/8	11/16	1 1/2	1/2	7/8-14	13/16	3/4-16	.968	1/2	—	W.F.	W.F.
	1 3/8	1 5/8	1 3/4	1 1/16	3/8	7/8	2	5/8	1 1/4-12	1 1/8	1-14	1.343	5/8	—	W.F.	W.F.
2 1/2	5/8	3/4	1 1/8	5/8	1/4	3/8	1 1/8	3/8	1/2-20	1/2	7/16-20	.594	1/4	9/32	W.F.	W.F.
	1	1 1/8	1 1/2	15/16	3/8	11/16	1 1/2	1/2	7/8-14	13/16	3/4-16	.968	1/2	17/32	W.F.	W.F.
	1 3/8	1 5/8	1 3/4	1 1/16	3/8	7/8	2	5/8	1 1/4-12	1 1/8	1-14	1.343	5/8	—	W.F.	W.F.
	1 3/4	2	2	15/16	1/2	1 1/8	2 3/8	3/4	1 1/2-12	1 1/2	1 1/4-12	1.703	3/4	—	W.F.	W.F.
3 1/4	1	1 1/8	1 1/2	15/16	3/8	11/16	1 1/2	1/2	7/8-14	13/16	3/4-16	.968	1/4	17/32	W.F.	W.F.
	1 3/8	1 5/8	1 3/4	1 1/16	3/8	7/8	2	5/8	1 1/4-12	1 1/8	1-14	1.343	3/8	13/32	W.F.	W.F.
	1 3/4	2	2	15/16	1/2	1 1/8	2 3/8	3/4	1 1/2-12	1 1/2	1 1/4-12	1.703	1/2	17/32	W.F.	W.F.
	2	2 1/4	2 5/8	1 11/16	5/8	1 3/8	2 5/8	7/8	1 3/4-12	1 5/8	1 1/2-12	1.953	1/2	—	W.F.	W.F.
4	1	1 1/8	1 1/2	15/16	3/8	11/16	1 1/2	1/2	7/8-14	13/16	3/4-16	.968	1/4	17/32	W.F.	W.F.
	1 3/8	1 5/8	1 3/4	1 1/16	3/8	7/8	2	5/8	1 1/4-12	1 1/8	1-14	1.343	3/8	13/32	W.F.	W.F.
	1 3/4	2	2	15/16	1/2	1 1/8	2 3/8	3/4	1 1/2-12	1 1/2	1 1/4-12	1.703	1/2	17/32	W.F.	W.F.
	2	2 1/4	2 5/8	1 11/16	5/8	1 3/8	2 5/8	7/8	1 3/4-12	1 5/8	1 1/2-12	1.953	1/2	17/32	W.F.	W.F.
	2 1/2	3	3 1/4	1 15/16	3/4	1 3/4	3 1/8	1	2 1/4-12	2 1/16	1 7/8-12	2.453	5/8	21/32	S.H.	W.F.
5	1	1 1/8	1 1/2	15/16	3/8	11/16	1 1/2	1/2	7/8-14	13/16	3/4-16	.968	1/4	17/32	W.F.	W.F.
	1 3/8	1 5/8	1 3/4	1 1/16	3/8	7/8	2	5/8	1 1/4-12	1 1/8	1-14	1.343	3/8	13/32	W.F.	W.F.
	1 3/4	2	2	15/16	1/2	1 1/8	2 3/8	3/4	1 1/2-12	1 1/2	1 1/4-12	1.703	1/2	17/32	W.F.	W.F.
	2	2 1/4	2 5/8	1 11/16	5/8	1 3/8	2 5/8	7/8	1 3/4-12	1 5/8	1 1/2-12	1.953	1/2	17/32	W.F.	W.F.
	2 1/2	3	3 1/4	1 15/16	3/4	1 3/4	3 1/8	1	2 1/4-12	2 1/16	1 7/8-12	2.453	1/2	21/32	S.H.	W.F.
	3	3 1/2	3 3/4	2 7/16	7/8	2 1/4	3 3/4	1	2 3/4-12	2 9/16	2 1/4-12	2.937	5/8	21/32	S.H.	W.F.
	3 1/2	3 1/2	4 3/8	2 11/16	1	2 1/2	4 1/4	1	3 1/4-12	3	2 1/2-12	3.437	5/8	17/32	S.H.	W.F.
6	1 3/8	1 5/8	1 3/4	1 1/16	3/8	7/8	2	5/8	1 1/4-12	1 1/8	1-14	1.343	1/4	13/32	W.F.	W.F.
	1 3/4	2	2	15/16	1/2	1 1/8	2 3/8	3/4	1 1/2-12	1 1/2	1 1/4-12	1.703	3/8	17/32	W.F.	W.F.
	2	2 1/4	2 5/8	1 11/16	5/8	1 3/8	2 5/8	7/8	1 3/4-12	1 5/8	1 1/2-12	1.953	3/8	17/32	W.F.	W.F.
	2 1/2	3	3 1/4	1 15/16	3/4	1 3/4	3 1/8	1	2 1/4-12	2 1/16	1 7/8-12	2.453	1/2	21/32	S.H.	W.F.
	3	3 1/2	3 3/4	2 7/16	7/8	2 1/4	3 3/4	1	2 3/4-12	2 9/16	2 1/4-12	2.937	1/2	21/32	S.H.	W.F.
	3 1/2	3 1/2	4 3/8	2 11/16	1	2 1/2	4 1/4	1	3 1/4-12	3	2 1/2-12	3.437	1/2	17/32	S.H.	W.F.
	4	4	4 1/2	2 11/16	1	3	4 3/4	1	3 3/4-12	3 7/16	3-12	3.937	1/2	17/32	S.H.	W.F.
7	1 3/8	1 5/8	1 3/4	1 1/16	3/8	7/8	2	5/8	1 1/4-12	1 1/8	1-14	1.343	—	—	W.F.	W.F.
	1 3/4	2	2	15/16	1/2	1 1/8	2 3/8	3/4	1 1/2-12	1 1/2	1 1/4-12	1.703	—	—	W.F.	W.F.
	2	2 1/4	2 5/8	1 11/16	5/8	1 3/8	2 5/8	7/8	1 3/4-12	1 5/8	1 1/2-12	1.953	—	—	W.F.	W.F.
	2 1/2	3	3 1/4	1 15/16	3/4	1 3/4	3 1/8	1	2 1/4-12	2 1/16	1 7/8-12	2.453	—	—	S.H.	W.F.
	3	3 1/2	3 3/4	2 7/16	7/8	2 1/4	3 3/4	1	2 3/4-12	2 9/16	2 1/4-12	2.937	—	—	S.H.	W.F.
	3 1/2	3 1/2	4 3/8	2 11/16	1	2 1/2	4 1/4	1	3 1/4-12	3	2 1/2-12	3.437	—	—	S.H.	W.F.
	4	4	4 1/2	2 11/16	1	3	4 3/4	1	3 3/4-12	3 7/16	3-12	3.937	—	—	S.H.	W.F.
8	1 3/8	1 5/8	1 3/4	1 1/16	3/8	7/8	2	5/8	1 1/4-12	1 1/8	1-14	1.343	—	—	W.F.	W.F.
	1 3/4	2	2	15/16	1/2	1 1/8	2 3/8	3/4	1 1/2-12	1 1/2	1 1/4-12	1.703	—	—	W.F.	W.F.
	2	2 1/4	2 5/8	1 11/16	5/8	1 3/8	2 5/8	7/8	1 3/4-12	1 5/8	1 1/2-12	1.953	—	—	W.F.	W.F.
	2 1/2	3	3 1/4	1 15/16	3/4	1 3/4	3 1/8	1	2 1/4-12	2 1/16	1 7/8-12	2.453	—	—	S.H.	W.F.
	3	3 1/2	3 3/4	2 7/16	7/8	2 1/4	3 3/4	1	2 3/4-12	2 9/16	2 1/4-12	2.937	—	—	S.H.	W.F.
	3 1/2	3 1/2	4 3/8	2 11/16	1	2 1/2	4 1/4	1	3 1/4-12	3	2 1/2-12	3.437	—	—	S.H.	W.F.
	4	4	4 1/2	2 11/16	1	3	4 3/4	1	3 3/4-12	3 7/16	3-12	3.937	—	—	S.H.	W.F.
	4 1/2	4 1/2	5 1/4	3 3/16	1 1/2	3 1/2	5 1/4	1	4 1/4-12	—	3 1/4-12	4.421	—	—	S.H.	S.H.
5	5	5 3/8	3 3/16	1 1/2	3 7/8	5 3/4	1	4 3/4-12	—	3 1/2-12	4.921	—	—	S.H.	S.H.	
5 1/2	5 1/2	6 1/4	3 15/16	1 7/8	4 3/8	6 1/4	1	5 1/4-12	—	4-12	5.421	—	—	S.H.	S.H.	

‡These dimensions for FF and FFX mounts only. For other mounts, use VA dimensions.

\*On FF and FFX mounts, use V dimensions.



**2 1/2 MH FF 25 CC W**

Bore	Cylinder Series	Mounting	Stroke	Cushion	Modification
As Required <hr/> Use Fractions Where Required	<b>A</b> Heavy Duty Pneumatic <b>AA</b> 200 PSI Pneumatic <b>CLA</b> Heavy Duty Pneumatic <b>CLH</b> Heavy Duty, 250 Pneumatic/1500 Hydraulic <b>C20</b> Heavy Duty Pneumatic, Cast Iron <b>HH</b> Heavy Duty Hydraulic <b>MA</b> Medium Duty Pneumatic <b>MH</b> Medium Pressure Hydraulic	Listed Below	As Required <hr/> Use Fractions Where Required <hr/> Shown as Gross Stroke Including Dual Piston or Stop Tube Length	<b>CF</b> – Cushion Front <b>CR</b> – Cushion Rear <b>CC</b> – Cushion Both Ends	<b>A</b> – Variation in Ports <b>D</b> – Double Rod Extension <b>K</b> – Any Variation in Rod from Standard. Any Variation from Standard Style 2 Rod End. <b>M</b> – Variation in Mounting <b>P</b> – NPT Ports <b>S</b> – Spring Return <b>V</b> – Viton Seals <b>W</b> – Water Fitted <b>Y</b> – Variation in Construction

### Mounting Styles

<b>BX</b> – Basic Cylinder, Tie Rods Extended, Both Ends	<b>FHF</b> – Front Head Flange	<b>RHF</b> – Rear Head Flange
<b>C</b> – Clevis	<b>FX</b> – Basic Cylinder, Tie Rods Extended, Front End	<b>RX</b> – Basic Cylinder, Tie Rods Extended, Rear End
<b>CL</b> – Center Line Lug	<b>NX</b> – Basic Cylinder, No Tie Rod Extension	<b>SF</b> – Side Flush
<b>EL</b> – End Lug	<b>P</b> – Pivot	<b>SL</b> – Side Lug
<b>FB</b> – Foot Bracket	<b>RF</b> – Rear Flange	<b>SP</b> – Sub Plate
<b>FF</b> – Front Flange	<b>RFX</b> – Rear Flange, Extra Size	<b>T</b> – Trunnion, Between Heads
<b>FFX</b> – Front Flange, Extra Size	<b>RH</b> – Rear Head (7" thru 14" A and MH - 16" thru 24" HH)	<b>TF</b> – Trunnion, Front
<b>FH</b> – Front Head (7" thru 14" A and MH - 16" thru 24" HH)		<b>TR</b> – Trunnion, Rear

### Order Information

To insure prompt delivery, please BE SURE TO INCLUDE THIS INFORMATION WHEN ORDERING:

- |  |   |   |
|--|---|---|
| 1. Quantity  | 8. Rod End Style (if other than Style 2 standard)   | 14. Medium (air, oil, water or other)                     |
| 2. Series  | 9. Rod Size (standard, oversize or 2:1)   | 15. Type of fluid   |
| 3. Bore  | 10. Extra Rod Extension (where required)  | 16. Operating Pressure and Maximum Shock Pressure         |
| 4. Stroke - Gross Stroke always shown in Model Number                          | 11. Port Size (if other than standard)  | 17. Temperature   |
| 5. Dual Piston or Stop Tube when necessary - always give Gross and Net Strokes | 12. Port Positions other than standard positions 1 and 5.   | 18. Double rod extension (when required)                  |
| 6. Mounting Style  | 13. Cushion check, adjusting screw, and bleed positions (when required) if other than standard positions. | 19. XI dimension on all Trunnion (between head) cylinders |
| 7. Cushion (front, rear, both or none)   |   | 20. Delivery required, or scheduling                      |

Complete and correct ordering information will eliminate untimely delays. When in doubt, always contact local distributor or factory. Contact distributor for helpful order or inquiry form.

#### Policy:

The policy of the Sheffer Corporation is one of continual improvement in design and manufacture to assure still finer products, hence, specifications are subject to change without notice.

#### Limited Warranty:

Sheffer warrants its products to be free from defects in material and workmanship for a period of one year from the date of shipment. This warranty does not cover field labor charges for parts removal and replacement, adjustments, repairs or other work, corrosion, electrolysis, mineral deposits or normal deterioration, misapplication, modification, or change in original operating conditions; components supplied by others; defects in parts resulting from abuse, negligence, neglect, accident, fire or explosion, or seals and other components subject to normal wear.

The sole and exclusive remedy against Sheffer shall be for the repair or replacement of parts returned transportation prepaid to Sheffer's factory and found by Sheffer to be defective. Replacement parts provided shall not extend the warranty period for said parts or for the total unit.

**IN CONSIDERATION OF THIS EXPRESS WARRANTY NO OTHER REMEDY (INCLUDING BUT NOT LIMITED TO INCIDENTAL OR CONSEQUENTIAL DAMAGES) SHALL BE AVAILABLE. THIS WARRANTY SHALL BE IN LIEU OF ANY AND ALL OTHER WARRANTIES, EXPRESS OR IMPLIED, INCLUDING, BUT NOT LIMITED TO, ANY IMPLIED WARRANTY OF MERCHANTABILITY OR FITNESS FOR A PARTICULAR PURPOSE, AND OF ALL OTHER OBLIGATIONS ON THE PART OF SHEFFER.**

Sheffer neither assumes, nor authorizes any person to assume for it, any other obligation or warranty.

# ▶ Conversions

## Fraction Equivalents

Fraction (inches)	Decimal (inches)	Metric (mm) (x 25.4)
1/64	.016	.4
1/32	.031	.8
3/64	.047	1.2
1/16	.062	1.6
5/64	.078	2.0
3/32	.094	2.4
7/64	.109	2.8
1/8	.125	3.2
9/64	.141	3.6
5/32	.156	4.0
11/64	.172	4.4
3/16	.187	4.7
13/64	.203	5.2
7/32	.219	5.6
15/64	.234	5.9
1/4	.250	6.3
17/64	.266	6.8
9/32	.281	7.1
19/64	.297	7.5
5/16	.312	7.9
21/64	.328	8.3
11/32	.344	8.7
23/64	.359	9.1
3/8	.375	9.5
25/64	.391	9.9
13/32	.406	10.3
27/64	.422	10.7
7/16	.437	11.1
29/64	.453	11.5
15/32	.469	11.9
31/64	.484	12.3
1/2	.500	12.7

Fraction (inches)	Decimal (inches)	Metric (mm) (x 25.4)
33/64	.516	13.1
17/32	.531	13.5
35/64	.547	13.9
9/16	.562	14.3
37/64	.578	14.7
19/32	.594	15.1
39/64	.609	15.5
5/8	.625	15.9
41/64	.641	16.3
21/32	.656	16.7
43/64	.672	17.1
11/16	.687	17.4
45/64	.703	17.9
23/32	.719	18.3
47/64	.734	18.6
3/4	.750	19.0
49/64	.766	19.5
25/32	.781	19.8
51/64	.797	20.2
13/16	.812	20.6
53/64	.828	21.0
27/32	.844	21.4
55/64	.859	21.8
7/8	.875	22.2
57/64	.891	22.6
29/32	.906	23.0
59/64	.922	23.4
15/16	.937	23.8
61/64	.953	24.2
31/32	.969	24.6
63/64	.984	25.0
1	1.000	25.4

## Temperature Equivalents

F°	C°
-30	-34.4
-20	-28.9
-10	-23.3
0	-17.8
10	-12.2
20	-6.7
30	-1.1
40	4.4
50	10.0
60	15.6
70	21.1
80	26.7
90	32.2
100	37.8
110	43.3
120	48.9
130	54.4
140	60.0
150	65.6
160	71.1
170	76.7
180	82.2
190	87.8
200	93.3
210	98.9
220	104.4
230	110.0
240	115.6
250	121.1
260	126.7

C°	F°
-30	-22
-20	-4
-10	14
0	32
5	41
10	50
15	59
20	68
25	77
30	86
35	95
40	104
45	113
50	122
55	131
60	140
65	149
70	158
75	167
80	176
85	185
90	194
95	203
100	212
105	221
110	230
115	239
120	248
125	257
130	266

$$C^{\circ} = (F^{\circ} - 32) \div 1.8$$

$$F^{\circ} = C^{\circ} \times 1.8 + 32$$

# ► Conversions

## Pressure Conversions

PSI	Kg/cm <sup>2</sup>	Bars
60	4.2	4.1
70	4.9	4.8
80	5.6	5.5
90	6.3	6.2
100	7.0	6.9
150	10.5	10.3
200	14.0	13.8
250	17.6	17.2
300	21.1	20.7
350	24.6	24.1
400	28.1	27.6
450	31.6	31.0
500	35.1	34.4
550	38.7	37.9
600	42.2	41.3
650	45.7	44.8
700	49.2	48.2
750	52.7	51.7
800	56.2	55.1
850	59.8	58.6
900	63.3	62.0
950	66.8	65.5
1000	70.3	68.9
1500	105.5	103.4
2000	140.6	137.8
2500	175.8	172.3
3000	210.9	206.7
3500	246.1	241.2
4000	281.2	275.6
4500	316.4	310.1
5000	351.5	344.5

Kg/cm<sup>2</sup> = PSI x .0703  
 Bars = PSI x .0689

Kg/cm <sup>2</sup>	PSI	Bars
4	56.9	3.9
5	71.1	4.9
6	85.3	5.9
7	99.5	6.9
8	113.8	7.8
9	128.0	8.8
10	142.2	9.8
20	284.4	19.6
30	426.6	29.4
40	568.8	39.2
50	711.0	49.0
60	853.2	58.8
70	995.4	68.6
80	1137.6	78.4
90	1279.8	88.2
100	1422.0	98.0
150	2133.0	147.0
200	2844.0	196.0
250	3555.0	245.0
300	4266.0	294.0
350	4977.0	343.0
400	5688.0	392.0

PSI = Kg/cm<sup>2</sup> x 14.22  
 Bars = Kg/cm<sup>2</sup> x .98

## Distance Conversions

Inches	cm	mm
1	2.5	25.4
2	5.1	50.8
3	7.6	76.2
4	10.2	101.6
5	12.7	127.0
6	15.2	152.4
7	17.8	177.8
8	20.3	203.2
9	22.9	228.6
10	25.4	254.0
15	38.1	381.0
20	50.8	508.0
25	63.5	635.0
30	76.2	762.0
35	88.9	889.0
40	101.6	1016.0
45	114.3	1143.0
50	127.0	1270.0
55	139.7	1397.0
60	152.4	1524.0
65	165.1	1651.0
70	177.8	1778.0
75	190.5	1905.0
80	203.2	2032.0
85	215.9	2159.0
90	228.6	2286.0
95	241.3	2413.0
100	254.0	2540.0

cm = in. x 2.54  
 mm = in. x 25.4

cm	Inches
1	.4
2	.8
3	1.2
4	1.6
5	2.0
6	2.4
7	2.8
8	3.1
9	3.5
10	3.9
20	7.9
30	11.8
40	15.8
50	19.7
60	23.6
70	27.6
80	31.5
90	35.5
100	39.4
110	43.3
120	47.3
130	51.2
140	55.2
150	59.1
160	63.0
170	67.0
180	70.9
190	74.9
200	78.8
210	82.7
220	86.7
230	90.6
240	94.6
250	98.5
260	102.4

in. = cm x .394