



***C20 SERIES
Cast Iron
Pneumatic
Cylinders***

Pressure Rating 200 PSI



1,2 Head and Cap

Fine grain, high tensile cast iron heads and caps are the finest that modern foundry skill can produce. They are machined to exacting standards.

3 Piston Rod

Piston rods have a minimum expected yield of 100,000 psi. They are ground, polished, and hard chrome plated for wear and corrosion resistance. Four wrench flats are standard.

4 Tube

The tube is a high tensile, special Aluminum alloy with a hard anodized finish. The file-hard finish offers long life and amazing lubrication holding properties. Also available in steel and fiberglass.

5 Tie Rods

Maximum strength is obtained through a prestressed tie rod assembly.

9 Piston

Pistons are machined from a fine grain alloy cast iron. They are of one piece design to give full thickness bearing and engineered for fast, positive inflation of seals.

16A Cushion Insert Seals

Cushion insert sandwiched between the tube and head (or cap) is sealed with a pressure-activated **O-RING (16A)**.

16B Tube End Seals

Static seals at tube ends are confined, precision cut gaskets.

18 Piston Seals

Modified U-cup seals are Buna-N compound. They are self-adjusting to pressure and wear and their design permits simple replacement – no need to disassemble the piston from the piston rod.

21 Rod Bearing

The replaceable rod bearing is made of oil impregnated sintered bronze for lubricated long life.

24 Rod Wiper

Synthetic wiper, steel encased, is designed to wipe off abrasive dust and contaminants on the retract stroke to insure long life for packings, rod bearing, and piston rod. This type of wiper is efficient, has low friction, and can be replaced without disassembly of the cylinder.

25 Rod Seal

Modified U-cup design offers long life with minimum friction. It is self-adjusting to pressure and wear. Seal material is a standard Buna-N compound. The rod seal can be replaced without disassembly of the cylinder.

30 Cushion Adjusting Screw

Is O-Ring sealed and can be rotated to any position for easy accessibility. When shipped, cushion adjusting screws will be in positions 1 and 5 (see PORT POSITIONS in Rod Ends and Porting Page 7).

33 A modified U-cup gives positive sealing during cushioning and free flow of air for rapid acceleration out of cushion. No check valve is needed.

71, 72 Cushions

C20 Series cylinders can be ordered with no cushions, cushioned front, cushioned rear, or cushioned both ends.

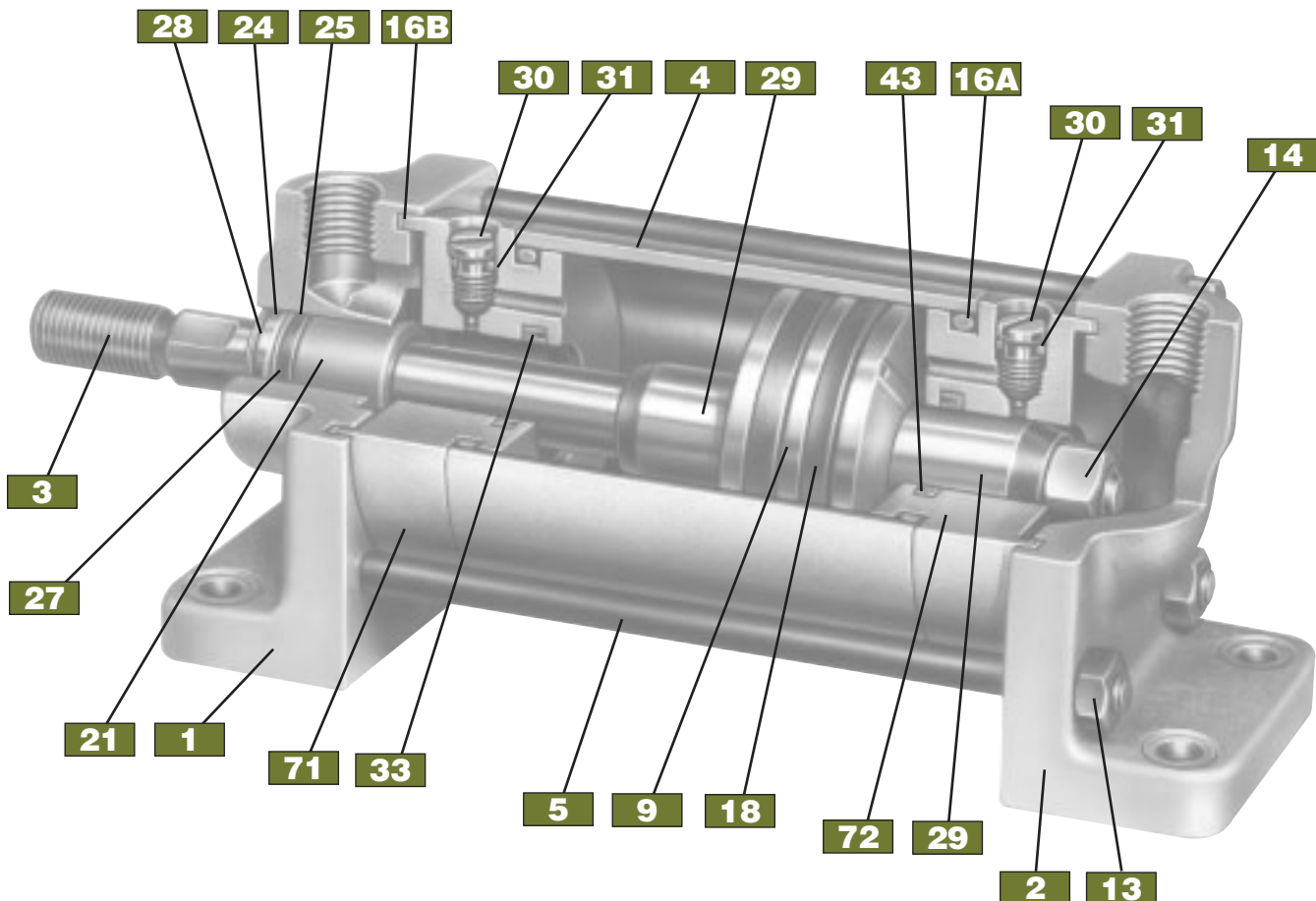

► Parts List

Parts List

ITEM NUMBER	DESCRIPTION	QUANTITY REQUIRED
1	HEAD	1
2	CAP	1
3	PISTON ROD	1
4	TUBE	1
5	TIE ROD	4, 6, 8
9	PISTON	1
13	TIE ROD NUT	‡
14	PISTON ROD NUT	1
16 A†	TUBE SEAL – O-RING	2
16 B†	TUBE SEAL – GASKET	2
18 †	PISTON SEAL	2
21 †	ROD BEARING	1
24 †	ROD WIPER	1
25	ROD PACKING	1
27	ROD PACKING SUPPORT WASHER	1
28	ROD PACKING RETAINING RING	1
29	CUSHION PISTON	**
30	CUSHION ADJ. SCREW	*
31 †	SEAL – CUSHION ADJ.	*
33 †	CUSHION SEAL – FRONT	*
43 †	CUSHION SEAL – REAR	*
71	CUSHION INSERT – FRONT	*
72	CUSHION INSERT – REAR	*
112	CLEVIS PIN AND RETAINERS	1
117	INTERMEDIATE TRUNNION	1

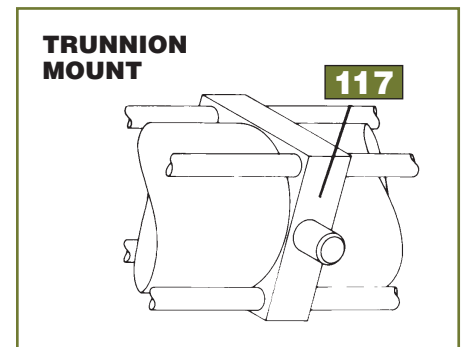
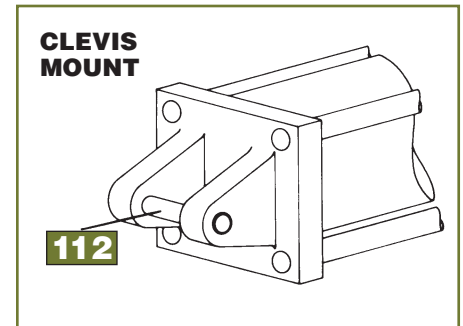

†Recommended Spare Parts

*As required: specify if cushioned front, cushioned rear or cushioned both ends.

**Used on all cushioned front cylinders. Used on cushioned rear cylinders bore sizes 1½" and 2" only.

‡As required – depends on bore size and mounting.

Theoretical Force in Pounds at Various Pressures (In PSI)

BORE	MM ROD DIA.	EFFEC-TIVE AREA PUSH	EFFEC-TIVE AREA PULL	50 PSI		80 PSI		90 PSI		100 PSI		150 PSI	
				PUSH	PULL	PUSH	PULL	PUSH	PULL	PUSH	PULL	PUSH	PULL
1½	½	1.767	1.571	88.4	78.6	141.4	125.7	159	141.4	176.7	157.1	265	235.6
2	½	3.14	2.946	157	147.3	251.2	235.7	282.6	265.1	314	294.6	471	441.9
2½	5/8	4.91	4.60	245.5	230	392.8	368	441.9	414	491	460	736.5	690
3	¾	7.07	6.63	353.5	331.5	565.6	530.4	636.3	596.7	707	663	1060	994.5
3½	¾	9.62	9.18	481	459	769.6	734.4	865.8	826.2	962	918	1443	1377
4	1	12.57	11.78	628.5	589	1006	942.4	1131	1060	1257	1178	1886	1767
5	1	19.64	18.85	982	942.5	1571	1508	1768	1696	1964	1885	2946	2828
6	1	28.27	27.49	1414	1374	2262	2199	2544	2474	2827	2749	4240	4124
7	1¼	38.49	37.26	1924	1863	3079	2981	3464	3353	3849	3726	5774	5589
8	1¾	50.27	48.78	2514	2439	4022	3902	4524	4390	5027	4878	7540	7317
10	1¾	78.54	76.13	3927	3807	6283	6090	7069	6852	7854	7613	11781	11420

FORCE DEVELOPED ON PUSH STROKE



Force (in lbs.) = Area of Piston (in sq. inches) times Pressure (in psi).

FORCE DEVELOPED ON PULL STROKE



Force (in lbs.) = Area of Piston (in sq. inches) less Area of Rod (in sq. inches) times Pressure (in psi).

CLEVIS MOUNT STYLE C

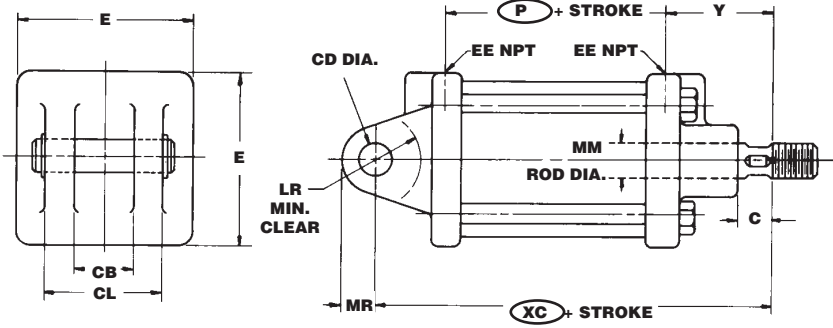

FOOT MOUNT STYLE F

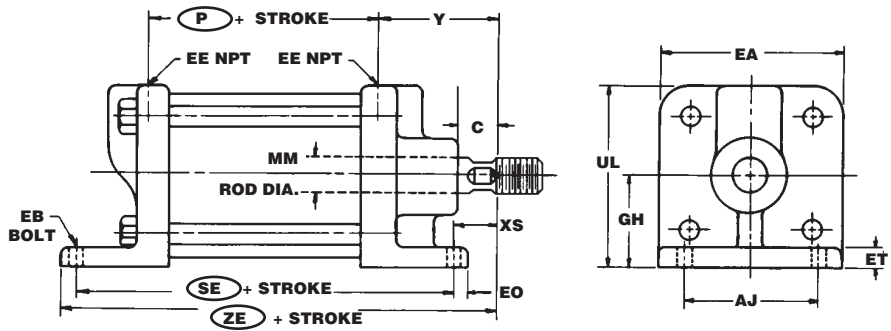

FRONT FLANGE MOUNT STYLE FF

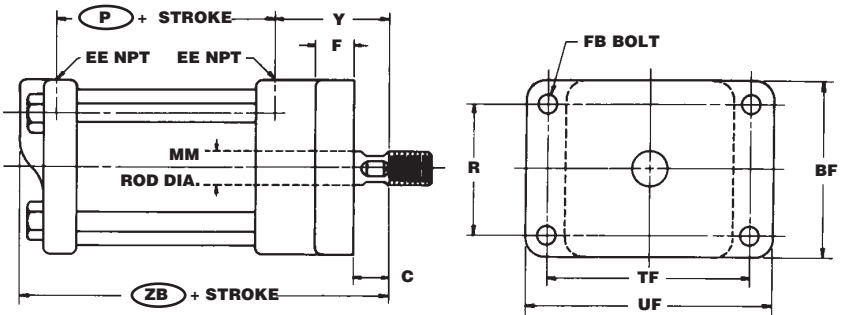

REAR FLANGE MOUNT STYLE RF

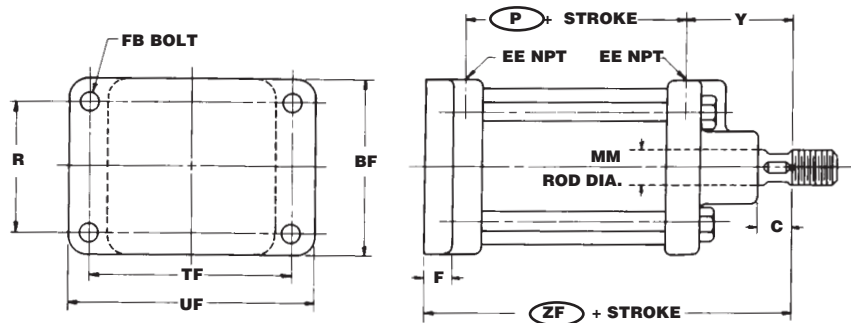

○ These dimensions are affected by addition of cushion. See Chart on page C20-5.

INTERMEDIATE TRUNNION MOUNT STYLE T

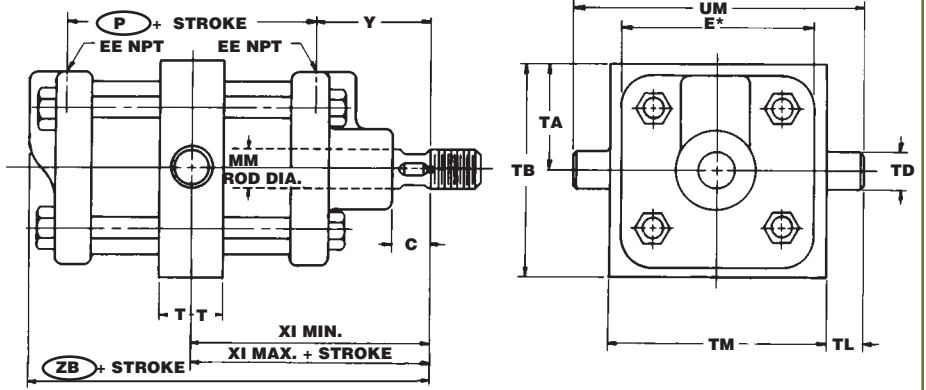
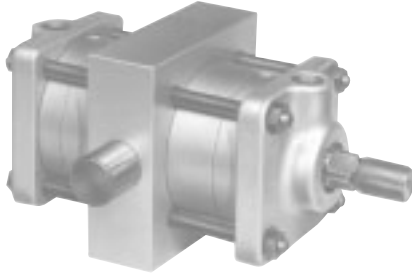

DOUBLE ROD END CYLINDER FOOT MOUNT STYLE F SUFFIX D

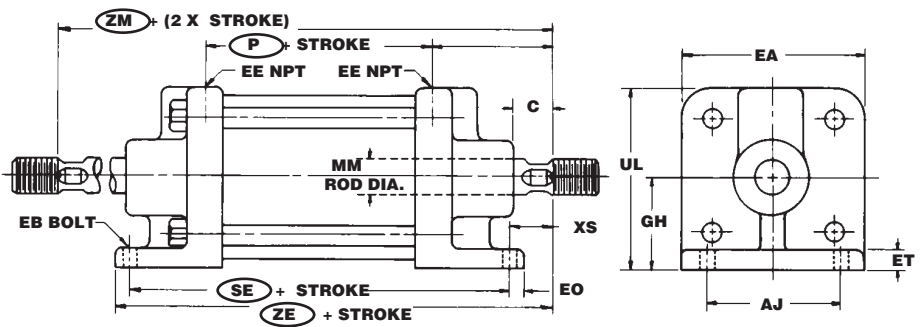

DOUBLE ROD END CYLINDER FRONT FLANGE MOUNT STYLE FF SUFFIX D

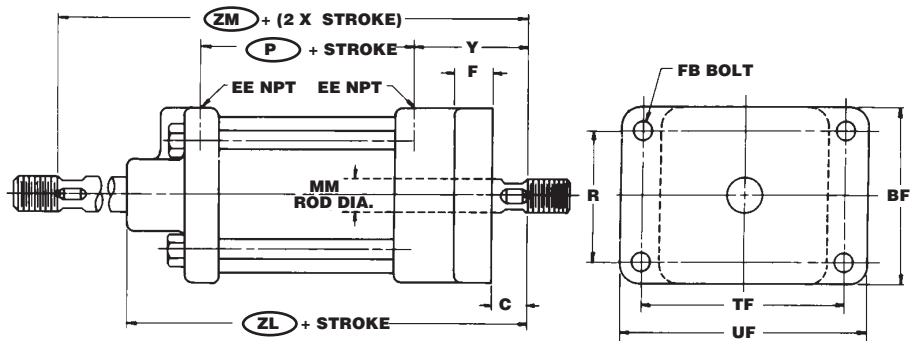

DOUBLE ROD END CYLINDER INTERMEDIATE TRUNNION MOUNT STYLE T SUFFIX D

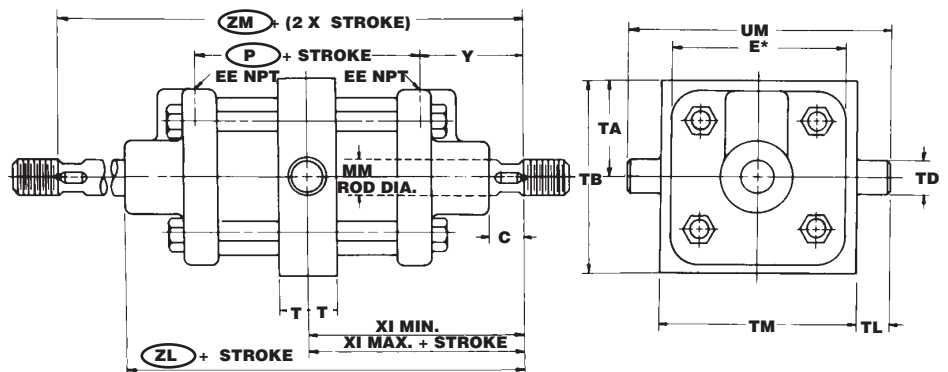
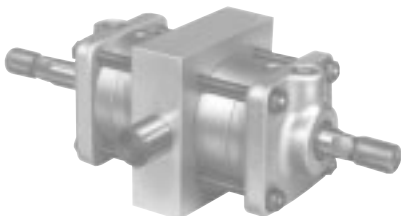

○ These dimensions are affected by addition of cushion. See Chart on page C20-5.
* For 4" and 5" Bores use BF dimension.

IMPORTANT

Trunnion Mount Cylinder

When ordering a Trunnion Mount cylinder, the XI dimension must be given to fix the position of the trunnion. The XI minimum is the shortest dimension that can be considered since it positions the trunnion right up against the head. When a cylinder is cushioned front, the trunnion would cover the cushion insert, allowing no access to the adjusting screw if the XI minimum dimension were specified. It is therefore recommended that, in such a case, the trunnion position be specified no closer to the head than the XI minimum plus the cushion insert thickness. The cushion insert thickness is given in the adjacent chart.

The XI maximum is a dimension that, when added to the stroke, would place the trunnion tight up against the cap of the cylinder. If a cylinder is cushioned front, the cushion insert thickness should be added to determine that maximum dimension. If the cylinder is cushioned rear or cushioned both ends, it is not recommended that the thickness of the rear cushion insert be added to determine the maximum XI dimension, since that would position the trunnion over the cushion rear insert, and access to the cushion adjusting screw would not be possible.

Double Rod End Cylinders

When the rod ends of a double rod end cylinder are not to be the same, such as a style 3 on one end and a style 4 on the other, be sure to specify and to identify which end is which in relation to the flange if cylinder is a Front Flange Mount.

Sheffer offers an extensive line of accessories to help facilitate mounting cylinders—See separate Accessories Brochure.

Non-Cushioned Cylinder Dimensions

BORE	1 1/2	2	2 1/2	3	3 1/2	4	5	6	7	8	10
AJ	1 1/4	1 5/8	2	2 1/2	2 7/8	4	4 3/4	5 3/4	5.73	6.44	—
BF	2	2 3/8	2 7/8	3 3/8	4	4 5/8	5 3/4	6 15/16	8	9	—
C	1 1/2	1 1/2	1 1/2	1 1/2	1 1/2	1 1/2	1 1/2	1 1/2	5/8	5/8	3/4
CB	3/4	3/4	3/4	1 1/4	1 1/4	1 1/4	1 1/4	1 1/2	1 1/2	1 1/2	2
CD	1/2	1/2	1/2	3/4	3/4	3/4	3/4	1	1	1	1 3/8
CL	1 3/4	1 3/4	1 3/4	2 1/2	2 1/2	2 1/2	2 1/2	3	3 1/4	4 1/4	4
E	2	2 3/8	2 7/8	3 3/8	4	4 1/2	5 1/2	6 15/16	8	9	11 1/2
EA	2	2 3/8	2 7/8	3 3/8	4	5 1/4	6 1/2	6 15/16	8	9	—
EB	1/4	1/4	5/16	3/8	3/8	3/8	1/2	1/2	5/8	5/8	3/4
EE	1/4	1/4	1/4	3/8	3/8	3/8	1/2	1/2	3/4	3/4	1
EH	—	—	—	—	—	—	—	—	—	—	11 5/8
EO	13/32	3/8	7/16	15/32	15/32	1/2	19/32	5/8	11/16	11/16	13/16
ET	5/16	3/8	7/16	1/2	1/2	1/2	5/8	5/8	1	1 1/4	1 1/4
F	3/8	3/8	7/16	7/16	7/16	7/16	5/8	5/8	7/8	1	1 1/4
FB	1/4	1/4	5/16	3/8	3/8	3/8	1/2	1/2	1/2	5/8	3/4
GH	1 1/2	1 5/8	2 1/8	2 1/4	2 1/2	2 7/8	3 3/8	3 5/8	4 1/8	4 5/8	5 7/8
LR	5/8	5/8	3/4	1 1/4	1 1/4	1 1/8	1 1/8	1 3/8	1 1/4	1 1/2	1 7/8
MM	1/2	1/2	5/8	3/4	3/4	1	1	1	1 3/8	1 3/8	1 3/4
MR	1/2	1/2	5/8	3/4	3/4	3/4	7/8	1 1/8	1	1	1 3/8
NA±.002	—	—	—	—	—	—	—	—	—	—	1.703
P	1 5/8	1 3/4	1 7/8	2	2	2 1/8	2 1/2	2 1/2	2 15/16	2 15/16	3 13/16
R	1 3/8	1 3/4	2 1/8	2 1/2	2 7/8	3 3/4	4 3/4	5 7/8	6 3/4	7.57	7.92
SE	2 5/8	2 3/4	3 1/8	3 1/4	3 1/2	3 1/2	3 11/16	3 11/16	5 7/8	5 7/8	7 7/16
TA	1 1/4	1 1/2	1 3/4	2 1/8	2 1/8	2 3/8	2 3/4	3 1/4	4	4 1/2	5
TB	2 1/2	3	3 1/2	4 1/4	4 3/4	5 1/2	6 1/2	8	9	10	—
TD	1	1	1	1	1	1	1	1 3/8	1 3/8	1 3/8	—
TE	—	—	—	—	—	—	—	—	—	—	9.40
TF	2 5/8	3	3 5/8	4 1/4	4 7/8	4 1/2	5 1/2	5 7/8	6 3/4	7.57	—
TL	1	1	1	1	1	1	1	1 3/8	1 3/8	1 3/8	—
TM	2 1/2	3	3 1/2	4 1/4	4 3/4	5 1/4	6 1/4	7 5/8	8 3/4	9 3/4	—
TT	1 1/4	1 1/2	1 1/2	1 1/2	1 1/2	1 1/2	1 1/2	1 3/4	1 3/4	1 3/4	—
UF	3 1/4	3 5/8	4 3/8	5 1/8	5 3/4	5 3/8	6 1/2	6 15/16	8	9	—
UL	2 1/2	2 13/16	3 9/16	3 15/16	4 1/2	5 9/16	6 1/4	7 1/8	8 1/8	9 1/8	—
UM	4 1/2	5	5 1/2	6 1/4	6 3/4	7 1/4	8 1/4	10 3/8	11 1/2	12 1/2	—
XC	3 7/8	4	4 1/16	4 3/4	4 3/4	4 13/16	5 1/8	5 1/8	6 1/8	7 1/8	8 7/8
XI MIN.	2 9/32	2 13/32	2 13/32	2 15/32	2 15/32	2 5/8	2 3/4	2 7/8	3 1/4	3 1/4	—
XI MAX.	1 23/32	1 19/32	1 23/32	1 25/32	1 25/32	1 15/16	2 1/4	2 1/8	2 11/16	2 11/16	—
XS	1 1/16	5/8	1/2	1/2	3/8	17/32	2 1/32	2 1/32	1 1/32	1 1/32	1/8
Y	1 3/16	1 1/8	1 1/8	1 1/8	1 1/8	1 7/32	1 1/4	1 1/4	1 1/2	1 1/2	1 15/16
ZB	3 1/4	3 3/8	3 1/2	3 11/16	3 11/16	3 15/16	4 3/8	4 3/8	5 1/4	5 1/4	6 13/16
ZE	3 23/32	3 3/4	4 1/16	4 7/32	4 11/32	4 17/32	4 15/16	4 31/32	6 19/32	6 19/32	8 3/8
ZF	3 5/16	3 7/16	3 9/16	3 3/4	3 3/4	4 1/16	4 7/16	4 7/16	5 5/16	5 5/16	6 15/16
ZL	3 1/2	3 1/2	3 5/8	3 3/4	3 3/4	4 1/16	4 1/2	4 1/2	5 5/16	5 5/16	6 15/16
ZM	4	4	4 1/8	4 1/4	4 1/4	4 9/16	5	5	5 15/16	5 15/16	7 11/16

Dimensions for Cushioned Cylinders

Adding a cushion or cushions to a cylinder increases overall length. A front cushion or a rear cushion adds 1" to all plus stroke dimensions for 1 1/2", 2", 2 1/2", 3", 3 1/2" and 4" bore sizes. For 5", 6", 7", 8" bore sizes, 1 1/4" is added and 10" bore sizes, 1 1/2" is added. The chart below shows dimensions for a cylinder cushioned either front or cushioned rear. See column at left titled IMPORTANT for information on cushioned trunnion cylinders.

Cushioned Either Front or Rear

BORE	1 1/2	2	2 1/2	3	3 1/2	4	5	6	7	8	10
P	2 5/8	2 3/4	2 7/8	3	3	3 1/8	3 3/4	3 3/4	4 3/16	4 3/16	5 5/16
SE	3 5/8	3 3/4	4 1/8	4 1/4	4 1/2	4 1/2	4 15/16	4 15/16	7 1/8	7 1/8	8 15/16
XC	4 7/8	5	5 1/16	5 3/4	5 3/4	5 13/16	6 3/8	6 3/8	7 3/8	8 3/8	10 3/8
ZB	4 1/4	4 3/8	4 1/2	4 11/16	4 11/16	4 15/16	5 5/8	5 5/8	6 1/2	6 1/2	8 5/16
ZC	—	—	—	—	—	—	—	—	—	—	11 3/4
ZE	4 23/32	4 3/4	5 1/16	5 7/32	5 11/32	5 17/32	6 3/16	6 7/32	7 27/32	7 27/32	9 7/8
ZF	4 5/16	4 7/16	4 9/16	4 3/4	4 3/4	5 1/16	5 11/16	5 11/16	6 9/16	6 9/16	8 7/16
ZL	4 1/2	4 1/2	4 5/8	4 3/4	4 3/4	5 1/16	5 3/4	5 3/4	6 9/16	6 9/16	8 3/16
ZM	5	5	5 1/8	5 1/4	5 1/4	5 9/16	6 1/4	6 1/4	7 3/16	7 3/16	8 7/16

Cushioning a cylinder on both ends adds 2" to all plus stroke dimensions in 1 1/2", 2", 2 1/2", 3", 3 1/2" and 4" bore sizes. For 5", 6", 7", 8" and 10" bore sizes, 2 1/2" is added. See Chart below for cushioned both ends dimensions. See column at left for information on cushioned Trunnion Mounts.

Cushioned Both Ends

BORE	1 1/2	2	2 1/2	3	3 1/2	4	5	6	7	8	10
P	3 5/8	3 3/4	3 7/8	4	4	4 1/8	5	5	5 7/16	5 7/16	6 13/16
SE	4 5/8	4 3/4	5 1/8	5 1/4	5 1/2	5 1/2	6 3/16	6 3/16	8 3/8	8 3/8	10 7/16
XC	5 7/8	6	6 1/16	6 3/4	6 3/4	6 13/16	7 5/8	7 5/8	8 5/8	9 5/8	11 7/8
ZB	5 1/4	5 3/8	5 1/2	5 11/16	5 11/16	5 15/16	6 7/8	6 7/8	7 3/4	7 3/4	9 13/16
ZE	5 23/32	5 3/4	6 1/16	6 7/32	6 11/32	6 17/32	7 7/16	7 15/32	9 3/32	9 3/32	11 3/8
ZF	5 5/16	5 7/16	5 9/16	5 3/4	5 3/4	6 1/16	6 15/16	6 15/16	7 13/16	7 13/16	9 15/16
ZL	5 1/2	5 1/2	5 5/8	5 3/4	5 3/4	6 1/16	7	7	7 13/16	7 13/16	9 7/16
ZM	6	6	6 1/8	6 1/4	6 1/4	6 9/16	7 1/2	7 1/2	8 7/16	8 7/16	10 3/16

► Model Number

COMPOSITION

	<u>2 1/2</u>	<u>C20</u>	<u>FF</u>	<u>25</u>	<u>CC</u>	<u>W</u>
Bore	Cylinder Series	Mounting	Stroke	Cushion	Modification	
As Required Use Fractions Where Required	A Heavy Duty Pneumatic AA 200 PSI Pneumatic CLA Heavy Duty Pneumatic CLH Heavy Duty, 250 Pneumatic/1500 Hydraulic C20 Heavy Duty Pneumatic, Cast Iron HH Heavy Duty Hydraulic MA Medium Duty Pneumatic MH Medium Pressure Hydraulic	Listed Below	As Required Use Fractions Where Required Shown as Gross Stroke Including Dual Piston or Stop Tube Length	CF – Cushion Front CR – Cushion Rear CC – Cushion Both Ends	A – Variation in Ports D – Double Rod Extension K – Any Variation in Rod from Standard. Any Variation from Standard Style 2 Rod End. M – Variation in Mounting P – NPT Ports S – Spring Return V – Viton Seals W – Water Fitted Y – Variation in Construction	

Mounting Styles		
BX – Basic Cylinder, Tie Rods Extended, Both Ends C – Clevis CL – Center Line Lug EL – End Lug FB – Foot Bracket FF – Front Flange FFX – Front Flange, Extra Size FH – Front Head (7" thru 14" A and MH - 16" thru 24" HH)	FHF – Front Head Flange FX – Basic Cylinder, Tie Rods Extended, Front End NX – Basic Cylinder, No Tie Rod Extension P – Pivot RF – Rear Flange RFX – Rear Flange, Extra Size RH – Rear Head (7" thru 14" A and MH - 16" thru 24" HH)	RHF – Rear Head Flange RX – Basic Cylinder, Tie Rods Extended, Rear End SF – Side Flush SL – Side Lug SP – Sub Plate T – Trunnion, Between Heads TF – Trunnion, Front TR – Trunnion, Rear

Order Information		
To insure prompt delivery, please BE SURE TO INCLUDE THIS INFORMATION WHEN ORDERING:		
1. Quantity 2. Series 3. Bore 4. Stroke - Gross Stroke always shown in Model Number 5. Dual Piston or Stop Tube when necessary - always give Gross and Net Strokes 6. Mounting Style 7. Cushion (front, rear, both or none)	8. Rod End Style (if other than Style 2 standard) 9. Rod Size (standard, oversize or 2:1) 10. Extra Rod Extension (where required) 11. Port Size (if other than standard) 12. Port Positions other than standard positions 1 and 5. 13. Cushion check, adjusting screw, and bleed positions (when required) if other than standard positions.	14. Medium (air, oil, water or other) 15. Type of fluid 16. Operating Pressure and Maximum Shock Pressure 17. Temperature 18. Double rod extension (when required) 19. XI dimension on all Trunnion (between head) cylinders 20. Delivery required, or scheduling
Complete and correct ordering information will eliminate untimely delays. When in doubt, always contact local distributor or factory. Contact distributor for helpful order or inquiry form.		

Policy:

The policy of the Sheffer Corporation is one of continual improvement in design and manufacture to assure still finer products, hence, specifications are subject to change without notice.

Limited Warranty:

Sheffer warrants its products to be free from defects in material and workmanship for a period of one year from the date of shipment. This warranty does not cover field labor charges for parts removal and replacement, adjustments, repairs or other work, corrosion, electrolysis, mineral deposits or normal deterioration, misapplication, modification, or change in original operating conditions; components supplied by others; defects in parts resulting from abuse, negligence, neglect, accident, fire or explosion, or seals and other components subject to normal wear.

The sole and exclusive remedy against Sheffer shall be for the repair or replacement of parts returned transportation prepaid to Sheffer's factory and found by Sheffer to be defective. Replacement parts provided shall not extend the warranty period for said parts or for the total unit.

IN CONSIDERATION OF THIS EXPRESS WARRANTY NO OTHER REMEDY (INCLUDING BUT NOT LIMITED TO INCIDENTAL OR CONSEQUENTIAL DAMAGES) SHALL BE AVAILABLE. THIS WARRANTY SHALL BE IN LIEU OF ANY AND ALL OTHER WARRANTIES, EXPRESS OR IMPLIED, INCLUDING, BUT NOT LIMITED TO, ANY IMPLIED WARRANTY OF MERCHANTABILITY OR FITNESS FOR A PARTICULAR PURPOSE, AND OF ALL OTHER OBLIGATIONS ON THE PART OF SHEFFER.

Sheffer neither assumes, nor authorizes any person to assume for it, any other obligation or warranty.

► Dimensions CUSHIONED AND NON-CUSHIONED CYLINDERS IN BORE SIZES 1 1/2" THRU 10"

Head, Cap and Trunnion Configurations

Bore Sizes 1 1/2", 2", 2 1/2", 3", 3 1/2", 4" and 5"

In bore sizes 1 1/2", 2", 2 1/2", 3" and 3 1/2", all mounts have square heads, caps and trunnions with four tie rods as pictured on Pages 3 and 4. This is also the case with the 4" and 5" bore sizes of the Clevis Mount. In bore sizes of 4" and 5", all mounts except clevis have hexagon heads with six tie rods as shown below. The intermediate trunnion in 4" and 5" bore sizes is round with milled flats for the trunnion pins.

Bore Sizes 6", 7", 8" and 10"

In bore sizes 6", 7", 8" and 10", all mounts have octagon heads and caps with eight tie rods as shown below. The intermediate trunnion is round with milled flats for the trunnion pins.

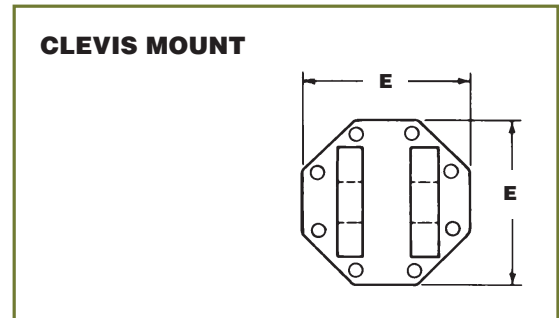
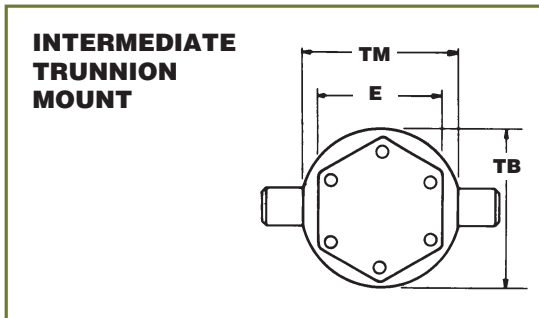
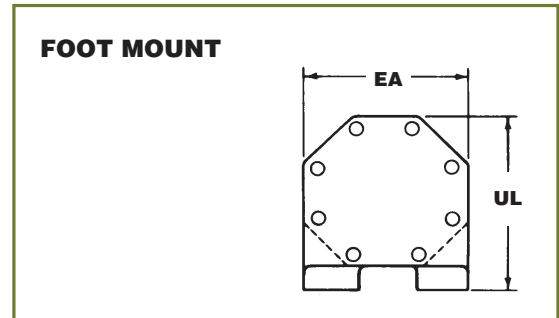
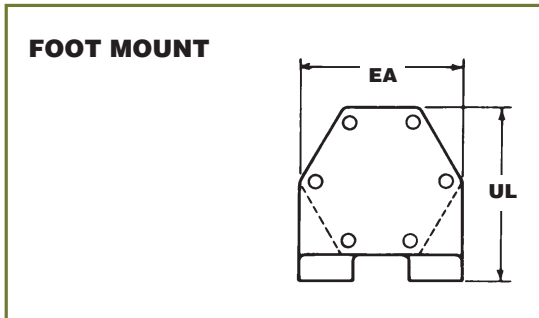
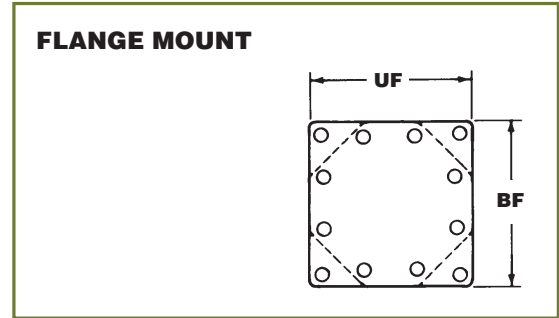
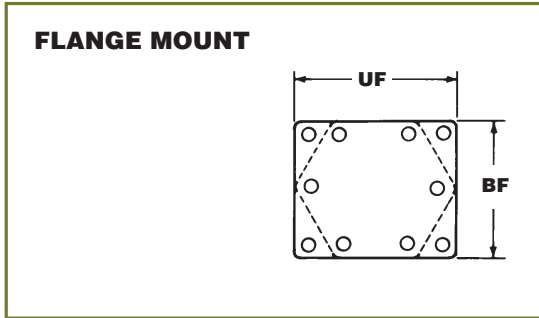

Tie Rod Torque Chart

CYLINDER BORE	TIE ROD SIZE	TORQUE IN FOOT LBS.
1 1/2	1/4	6
2	1/4	6
2 1/2	5/16	15
3	5/16	15
3 1/2	5/16	15
4	5/16	15
	(4) 3/8	25
5	3/8	25
	(4) 1/2	40
6	3/8	25
7	3/8	25
8	3/8	25
10	1/2	50

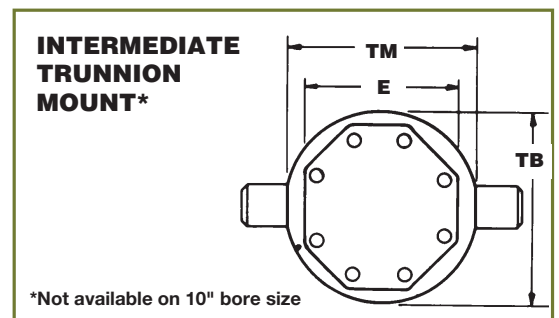

Rod Ends and Porting

200 PSI

Alternate - Style 1 Plain male Rod End with no threads. Used for pushing, holding knockouts, etc.

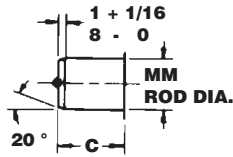

IMPORTANT

Style 3 Rod End is standard and will be furnished unless otherwise specified. Alternate Rod End Styles 1, 2, 4 and 6 are available at no extra cost. Special rod end configurations are available for a nominal extra charge. A wide selection of rod end accessories is shown in separate Accessories Brochure.

Alternate - Style 4 Female thread, used with male accessories for shorter over-all cylinder length.

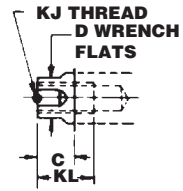

Alternate - Style 2 Male thread with adequate shoulder for locking accessory.

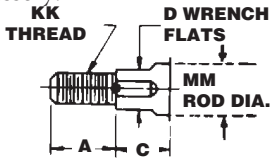

STANDARD - STYLE 3 Male thread same diameter as Piston Rod. No shoulder for locking accessories.

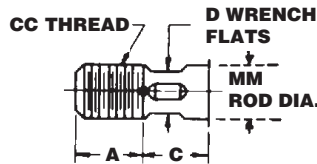

Alternate - Style 6 Used with S.A.F.E. accessory (see separate Accessories Brochure) for fast, close radial alignment.

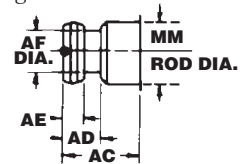

Rod End Dimensions

BORE	MM ROD DIA.	A	AC	AD	AE	AF	C	CC	D	KJ	KK	KL
1 1/2	1/2	1	1	1/2	3/16	5/16	1/2	1/2-20	7/16	5/16-24	3/8-24	5/8
2	1/2	1	1	1/2	3/16	5/16	1/2	1/2-20	7/16	5/16-24	3/8-24	5/8
2 1/2	5/8	1	1 1/8	5/8	1/4	3/8	1/2	5/8-18	1/2	7/16-20	1/2-20	7/8
3	3/4	1 1/8	1 1/4	11/16	5/16	7/16	1/2	3/4-16	5/8	1/2-20	5/8-18	7/8
3 1/2	3/4	1 1/8	1 1/4	11/16	5/16	7/16	1/2	3/4-16	5/8	1/2-20	5/8-18	7/8
4	1	1 1/2	1 1/2	15/16	3/8	11/16	1/2	1-14	7/8	3/4-16	3/4-16	1
5	1	1 1/2	1 1/2	15/16	3/8	11/16	1/2	1-14	7/8	3/4-16	3/4-16	1
6	1	1 1/2	1 1/2	15/16	3/8	11/16	1/2	1-14	7/8	3/4-16	3/4-16	1
7	1 3/8	2	1 3/4	11/16	3/8	7/8	5/8	1 1/4-12	1 1/8	7/8-14	1-14	1 1/2
8	1 3/8	2	1 3/4	11/16	3/8	7/8	5/8	1 3/8-12	1 1/8	1-14	1-14	1 1/2
10	1 3/4	2	—	—	—	—	3/4	1 1/2-12	1 1/2	—	1 1/4-12	—

Port Positions

Bore Sizes 1 1/2", 2", 2 1/2", 3" and 3 1/2" all mounts. Also 4" and 5" of Clevis Mount

Bore Sizes 4" and 5" all mounts except Clevis

Bore Sizes 6", 7" 8" and 10" all mounts

Standard port positions are 1 and 5. Unless otherwise specified, ports will be supplied in those positions.

Alternate Port Positions

CLEVIS MOUNT	FRONT FOOT MOUNT	REAR FLANGE MOUNT	FLANGE MOUNT	INTER-MEDIATE TRUNNION MOUNT
HEAD CAP	HEAD CAP	HEAD CAP	HEAD CAP	HEAD CAP
2, 3, 4, 7	-	3, 6, 7, 8	2, 3, 4, 7	2, 3, 4, 6, 7, 8

Optional Port Positions

CLEVIS MOUNT	FRONT FOOT MOUNT	REAR FLANGE MOUNT	FLANGE MOUNT	INTER-MEDIATE TRUNNION MOUNT
HEAD CAP	HEAD CAP	HEAD CAP	HEAD CAP	HEAD CAP
-	6, 8	2, 4, 6, 8	2, 4	-

Alternate port positions, are those that can be accomplished by rotating the head and/or the cap. There is no extra charge for these positions but they must be specified on your order.

Alternate and Optional positions available are indicated in the charts above.

Optional port positions are those that can be accomplished by drilling and tapping auxiliary bosses on the castings. Since heads and caps in stock are already ported in the standard positions, the standard parts must be plugged. There is a small additional charge for plugging and re-porting. In cases of large quantity orders, a special run of castings can be machined with ports in the desired optional positions. Optional positions must be specified on your orders.



The Sheffer Corporation
6990 Cornell Road • Cincinnati, Ohio 45242
(513) 489-9770 • Fax: (513) 489-3034
www.sheffercorp.com